

AMERICAN ASSOCIATION OF SHERIFF POSSES AND RIDING  
CLUBS

BOWIE, TEXAS

**OFFICIAL MANUAL 2026**



THE FRATERNITY OF HORSEMANSHIP SPORTSMANSHIP  
& CITIZENSHIP

By-Laws

Parade

Scrapbook

Playdays

# American Association of Sheriff Poses and Riding Clubs

## PAST QUEENS

2021 Miss Samantha Boyce  
2020 Miss Abby Walker  
2011 Miss Lauren O'Brien  
2010 Miss Joy Mainville  
2009 Miss Ali Burks  
2008 Miss Delci Willis  
2007 Miss Melissa Tichenor  
2006 Miss Becky Smith  
2005 Miss K.D. Foltz  
2003 Miss Shallon May  
2002 Miss Christy Sloan  
2001 Miss Jackie Bailey  
2000 Miss Rachael Hatfield  
1999 Miss Sara Braden  
1998 Miss Stephanie Miller  
1997 Miss Suzanne Hall  
1996 Miss Summer Wilson  
1995 Miss Stephanie Husky  
1994 Miss Kim Carver  
1993 Miss Amber Busby  
1992 Miss Kristen Hatchett  
1991 Miss Angel Roberts  
1990 Miss Jackie Dunlap  
1989 Miss Robin Hurta  
1988 Miss Charlotte Morse  
1987 Miss Becca Burnett  
1986 Miss Tonja Honeycutt  
1985 Miss Heather Bowling  
1984 Miss Tracy McPherson  
1983 Miss Kim O'Neal

1982 Miss Tammy Kocian  
1981 Miss Julie Johnson  
1980 Miss Susan Toups  
1979 Miss Becky Albers  
1978 Miss Renee Crisp  
1977 Miss Denise Fuchshuber  
1976 Miss Cindy Heaslet  
1975 Miss Lynda Rae  
1974 Miss Cindy Shanklin  
1973 Miss Teri Jo Percell  
1972 Miss Cheryl Spindle  
1971 Miss Christine Wallace  
1970 Miss Toni Chamness  
1969 Miss Janice Allen  
1968 Miss Cindy Garvin  
1967 Miss Carolyn Coker  
1966 Miss Schrenia Clark  
1965 Miss Patty Hamlett  
1964 Miss Pati Englerth  
1963 Miss Cathy Leftwich  
1962 Miss Anita Bevins  
1961 Miss Joan Baker  
1960 Miss Earlene Foreman  
1959 Name Unknown  
1958 Miss Diane Case  
1957 Name Unknown  
1956 Name Unknown  
1955 Name Unknown  
1954 Name Unknown  
1953 Miss Doris Ratliff

# American Association of Sheriff Posses and Riding Clubs

## PAST PRESIDENTS

### Year Served

1952-57 \*\*Crate Snider (dec.) O.  
1958 R. Clark (dec.)  
1959 Hap Hovenkamp (dec.)  
1960-62 \*\*Crate Snider (dec.)  
1963 Jim Fletcher (dec.)  
1964-65 Albert Fortenberry  
1966-67 Zip Taylor  
1968 Clark Jarnagan (dec.)  
1969-70 Bob Morse (dec.)  
1971-72 R. B. Allen  
1973 Dee Morgan (dec.)  
1974-75 \*\*Jack McClung  
1976 Charles Bell

1977-78 \*\*Garland Hargis (dec.)  
1979 Bill Jeter  
1980-81 Junior Oates  
1982-83 Gary Murphy

1984 \*\*Gene Montgomery (dec)  
1985-86 Gene Worthington  
1987 Weldon Garrett (dec.)

1988-89 Gerald Goldson  
1990-91 Birk Hendrix  
1992-93 \*\*Garland Hargis (dec.)  
1994 \*\*Jack McClung

1995-96 Billy Privett  
1997 R. E. (Bob) Myers  
1998 Bill Stone (dec.)  
1999 Al Taylor (dec.)  
2000-01 \*\*Gene Montgomery (dec.)  
2002-03 \*\*Tommy McEwen  
2004-05 Dave Roberts (dec.)  
2006 Larry Mitchell  
2007-08 Annette Waggoner  
2009 \*\*Tommy McEwen  
2010 -11 Donna Leipsic  
2011-2012 Renee Guthrie (dec.)  
2012-2013 U.B. Herrington

2013-2014 U.B. Herrington  
2014-2015 U.B. Herrington  
2015-2016 Buster Jones  
2017-2018 Todd Blackburn

2018-2019 Todd Blackburn  
2019-2020 Tommy McEwen  
2020-2021 Tommy McEwen

2021-2022 Todd Blackburn  
2022-2023 Lisa McLeroy  
2023-2024 Lisa McLeroy  
2024-2026 Lisa McLeroy

## Table of Contents

<b>PAST QUEENS</b> .....	<b>2</b>
<b>PAST PRESIDENTS</b> .....	<b>3</b>
<b>FOREWORD</b> .....	<b>6</b>
<b>ARTICLE I – TITLE, OBJECTIVE, PLACE OF BUSINESS</b> .....	<b>7</b>
SECTION 1 TITLE .....	7
SECTION 2 OBJECTIVE.....	7
SECTION 3 PLACE OF BUSINESS .....	7
<b>ARTICLE II - MEMBERS</b> .....	<b>7</b>
SECTION 1 MEMBERSHIP .....	7
SECTION 2 RULES.....	7
SECTION 3 QUALIFICATIONS .....	8
SECTION 4 RIGHTS.....	8
SECTION 5 DUES .....	8
<b>ARTICLE III - DELEGATES</b> .....	<b>8</b>
SECTION 1 DELEGATES.....	8
SECTION 2 LETTER OF CERTIFICATION .....	9
SECTION 3 MEETINGS .....	9
SECTION 4 SPECIAL MEETINGS.....	9
SECTION 5 QUORUM .....	9
<b>ARTICLE IV – OFFICERS</b> .....	<b>9</b>
SECTION 1 OFFICERS .....	9
SECTION 2 PRESIDENT .....	10
SECTION 3 EXECUTIVE VICE PRESIDENT .....	10
SECTION 4 IMMEDIATE PAST PRESIDENT .....	10
SECTION 5 REGIONAL VICE PRESIDENT.....	10
SECTION 6 ASSOCIATION QUEEN.....	11
<b>ARTICLE V – AUDITING, BONDS, MONIES</b> .....	<b>13</b>
SECTION 1 AUDITING .....	13
SECTION 2 SURETY BONDS .....	13
SECTION 3 MONIES AND ACCOUNTS .....	13
<b>ARTICLE VI – STANDING COMMITTEES</b> .....	<b>13</b>
SECTION 1 COMMITTEE MEMBERSHIP .....	13
SECTION 2 COMMITTEES .....	13
SECTION 3 QUORUM .....	14
SECTION 4 CREDENTIALS .....	14
SECTION 5 SPECIAL COMMITTEE.....	15

SECTION 6 EXECUTIVE BOARD .....	15
<b>ARTICLE VII – OPERATING PROCEDURES .....</b>	<b>15</b>
SECTION 1 DUTIES OF OFFICERS .....	15
SECTION 2 QUARTERLY OFFICERS MEETINGS .....	16
SECTION 3 COMMITTEES .....	16
SECTION 4 ASSOCIATION SPONSORED FUNCTIONS .....	16
SECTION 5 REGION .....	18
SECTION 6 DISTRICTS .....	18
SECTION 7 CLUBS .....	19
SECTION 8 GENERAL RULES .....	19
<b>ARTICLE VIII AMENDMENTS .....</b>	<b>20</b>
SECTION 1- MAKE, AMEND & REPEAL .....	20
SECTION 2- EMERGENCY .....	20
SECTION 3-ABEYANCE .....	20
SECTION 4-CHANGES DISTRIBUTED .....	20
<b>APPLICATION FOR MEMBERSHIP .....</b>	<b>22</b>
<b>PARADES .....</b>	<b>24</b>
<b>CLUB PARADE REPORT FORM .....</b>	<b>27</b>
<b>PARADE ANNOUNCEMENT FORM .....</b>	<b>28</b>
<b>SCRAPBOOK .....</b>	<b>29</b>
<b>PLAYDAY GAMES .....</b>	<b>30</b>
BARREL RACE.....	35
STRAIGHT AWAY BARRELS .....	36
PYLON ALLEY .....	37
SPUR.....	38
QUARTER HORSE POLES.....	39
DOUBLE BARREL FLAG RACE.....	40
BASEBALL.....	41
FLYING W RACE .....	42
LAZY H.....	43
PEPPERMINT TWIST.....	44
HITCH & GO.....	45
LARRYETTE.....	46
BOW TIE.....	47
<b>COPYRIGHT AND REVISION DATES .....</b>	<b>48</b>

# **AMERICAN ASSOCIATION OF SHERIFF POSSES AND RIDING CLUBS, INC.**

## **FOREWORD**

The American Association of Sheriff Poses and Riding Clubs was organized in December, 1952 as the West Texas Association of Sheriff Poses and Riding Clubs, when a group of representatives from Sheriff Poses and Riding Clubs met to compile rules for judging parades.

There were 13 charter members.

The name was changed at a director's meeting during the 1955 Roundup to "American Association of Sheriff Poses and Riding Clubs", because of the interest shown over a much wider area. The AASP&RC is a national organization; however, the major part of our membership is in Texas and Oklahoma.

The Association's motto is "Horsemanship, Sportsmanship, and Citizenship". The purpose of the Association shall be to encourage the use of this motto and keep alive "The Spirit of the Old West".

The Association has a convention each year, at which Delegates gather to resolve the problems of the past year, set policies, elect officers for the coming year and present awards. A queen is selected at this meeting to reign over the Association for the coming year as an honorary officer.

The Association holds an Annual Roundup in the spring. Activities at the Roundup include horseback games, trail rides, dances, barbecues, church services, etc. In addition, those who wish to do so, may camp out in true Western Style.

Due to the growth of the Association, Districts were formed and District Headquarters designated. These Headquarters have the function of establishing a District for the convenience of riding clubs in the area. Each member club in the District elects two Delegates, who in turn elect District Officers and Regional Board as well as Association Officers.

Districts are organized into Regions for better operation of Association activities. The governing board of each Region is elected by the club delegates.

All clubs that would like to become members of the Association may obtain application forms from the Association office. Additional information may be obtained from any officer or board member of the Association. The official publication of the Association is the "Riders Roundup", which is published monthly. This publication serves as the principal means of communication between the Association headquarters and the membership. Special bulletins for special events may be mailed when necessary.

### **HELPFUL HINTS FOR NEW MEMBER CLUBS**

1. Set up a good set of by-laws and enforce them. When you relax them, you are deteriorating.
2. Keep down drinking in uniform. See General Rules: Language, Alcohol, and Conduct.
3. Set up an equipment committee to select your uniforms and also pass on your horses. Inspect horses of members and prospective members and assist them in obtaining the right kinds of horses to suit your club needs. Too much money is spent on inferior kinds of horseflesh.
4. Enter into all activities of your District as a Posse or Club. Mix with other Poses and Clubs. The fellowship and interest created will be invaluable.
5. Elect two delegates to represent and vote for your club at the District, Region and National levels.
6. It is the club's responsibility to keep the Association informed of the club activities in order that these ideas may be exchanged with others.
7. Sportsmanship is your best weapon, use it.

# AMERICAN ASSOCIATION OF SHERIFF POSSES AND RIDING CLUBS, INC.

## ARTICLE I – TITLE, OBJECTIVE, PLACE OF BUSINESS

### SECTION 1 TITLE

This Association shall be known as **THE AMERICAN ASSOCIATION OF SHERIFF POSSES AND RIDING CLUBS, INC.** and shall be operated and conducted as a not-for-profit organization.

### SECTION 2 OBJECTIVE

The purposes of this organization shall be to encourage the motto of "Horsemanship, Sportsmanship and Citizenship", and to keep alive "The Spirit of the Old West". It shall promote the acquaintance and friendship among member posses and clubs through the sponsoring of activities related to mounted sports.

### SECTION 3 PLACE OF BUSINESS

The principal place of business shall be designated as the Association Headquarters. Its members and officers may be residents of any State or Territory. Business may be transacted at any place convenient to such members or officers. ~

## ARTICLE II - MEMBERS

### SECTION 1 MEMBERSHIP

- A. **Membership** A member, as referred to in these By-Laws, shall be any Sheriff Posse, Riding Club or other organized riding group. An individual is affiliated with the Association by his membership in a member club.
- B. **Sponsorship** A member or family may sponsor a child and include the child under their membership. A child or sponsored child may only be added to one-member family, and a family may only have 1 child sponsored.
- C. **Business Associate Membership.** Any business or concern may be an Associate Member with the approval of the Executive Board. (The annual fee of \$25.00 has been set by the Executive Board).
- D. **Individual Associate Membership.** Any individual may be an Associate Member with the approval of the Executive Board. He may enjoy all of the rights and privileges of the Association, except the right to vote, hold office and compete in Association competition. (The annual fee of \$10.00 has been set by the Executive Board.)
- E. **Lifetime Members**

A Lifetime Member shall enjoy all the rights and privileges of the Association as long as such individual remains a member in good standing of an Association affiliated club. The sale of Lifetime Memberships are non transferable and non refundable.

- 1. A Lifetime Member shall enjoy all the rights and privileges of the Association as long as such individual remains a member in good standing of an Association affiliated club.
- 2. The sale of Lifetime Memberships are non transferable and non refundable.
- 3. The sale of Lifetime Memberships shall be authorized by the delegates

### F. Associate Lifetime Members

- 1. Associate Lifetime Members or a Business may become a Lifetime Associate Member and enjoy all the rights and privileges of the Association except the right to vote and hold office and compete in Association competition.
- 2. The sale of Lifetime Associate Memberships shall be authorized by the delegates.

### SECTION 2 RULES

Members of the Association shall be admitted, retained and expelled in accordance with such rules and regulations as the Delegates may, from time to time, adopt.

**SECTION 3 QUALIFICATIONS**

New members clubs or delinquent clubs requesting reactivation must be recommended by a District in good standing in the Association and shall be admitted to the Association upon the following:

1. Written application
2. Initiation Fee
3. Club Dues
4. List of family members as follows:

---

Last Name	Given Name	Date of Birth, Sex, Class
-----------	------------	---------------------------

---

Last Name	Given Name	Date of Birth, Sex, Class
-----------	------------	---------------------------

---

Last Name	Given Name	Date of Birth, Sex, Class
-----------	------------	---------------------------

---

Mailing Address	City	State, Zip
-----------------	------	------------

---

Home Phone	Business Phone
------------	----------------

5. Approval of Regional Vice President. Membership shall begin when all of sec. 3 has been completed.
6. A club wishing to enter under an established District requires no minimum number of members.

**SECTION 4 RIGHTS**

All Members, while in good standing, shall have equal rights, interest, and responsibilities, with respect to the Association and its property.

**SECTION 5 DUES**

The annual dues shall be \$75.00 per family. They are due January 1<sup>st</sup>. After March 1<sup>st</sup>, there will be a \$25.00 late fee. Lifetime members are asked to donate \$10.00 each year. New families shall pay \$40.00 for their first year. (A family will include parents, domestic partner according to Texas Law or legal guardian and unmarried children living as a household, or sponsored child. When a child marries or reaches the age of 21 years unless in the military or full time student, a new immediate family is formed. If they are in the military or a full time student, an individual membership starts at age 25.)

The membership fee includes a subscription to the Riders Roundup as long as the family is a member in good standing with the club and the Association.

There is an initiation fee of \$15.00 for all new or delinquent clubs to bear a part of the expense of recording the membership.

**ARTICLE III - DELEGATES**

**SECTION 1 DELEGATES**

There shall be 2 Club Delegates and 1 District Delegate from every Club and District. The business and property of the Association shall be managed and controlled by: (1) The Delegates, and (2) Executive Board herein created and empowered. Each delegate shall be elected or appointed for a term of one year and shall serve until his successor has been duly elected or appointed and qualified. All delegates that are not properly registered as such in the records in the Association office shall submit to the

chairman, a letter of certification of voting privileges signed by at least two officers of the club which he represents. Proxy votes are not acceptable.

#### **SECTION 2 LETTER OF CERTIFICATION**

In the event a letter of certification is not available at any meeting of the Delegates, two officers of the club in question may sign a statement, verifying to the Credentials Committee, the eligibility of its Delegates.

#### **SECTION 3 MEETINGS**

The annual meeting of the Delegates shall be held at the annual Convention. No notice shall be required. At this meeting, the Delegates shall elect the officers of the Association and conduct any other business of the Association.

#### **SECTION 4 SPECIAL MEETINGS**

Special meetings of the Delegates may be held at such time and place as may be designated by the President, or twenty percent (20%) of the Delegates. Notice of such a special meeting, including the purpose thereof, shall be given not less than fifteen (15) days prior to the date of the meeting

#### **SECTION 5 QUORUM**

At any meeting of the Delegates, called in accordance with the foregoing provisions, the Delegates in attendance shall constitute a quorum.

Any officer of the Association may call the meeting of the Delegates to order, and may act as chairman of such meeting, precedence given as follows: President, Executive Vice President, Treasurer, Immediate Past President, Vice President in order of precedence to be indicated by vote of the Delegates present. In the absence of all such officers, the Delegates present may elect a chairman.

### **ARTICLE IV – OFFICERS**

#### **SECTION 1 OFFICERS**

- A. The officers shall be President, Executive Vice President, Treasurer, Immediate Past President, Regional Vice Presidents, and such other officers as may be authorized by the Executive Board. (See Section I of Operating Procedures).
- B. The President, Executive Vice President and Treasurer of the Association shall be elected for a period of two (2) year, with a two (2) term limit, and must meet the minimum experience requirements specified below. The Regional Vice Presidents shall be elected by the Club Delegates within their respective Regions and shall represent the Association as the chief officer within that Region. The Regional Vice Presidents shall be elected for a term of two years, which terms shall be staggered to prevent having a large majority of new officers in any given year. The Regional Vice Presidents of odd numbered Regions shall be elected to terms commencing on odd numbered years and the Regional Vice Presidents of even numbered Regions shall be elected to terms commencing on even numbered years.
- C. The new officers of the Association will assume responsibilities of their offices immediately upon being sworn in.
- D. No two members of the same family may serve as officers at the same time. (A family will include parents or legal guardians and unmarried children living as a household. When a child marries or reaches the age of 21 years unless in the military or full-time student, a new immediate family is formed. If they are in the military or full-time student, an individual membership starts at age 25.) Also no two members of the same family can be on the checking account at the same time.
- E. Officers of the Association will be offered camper hook ups/spaces on the grounds free of charge.
- F. If an elected officer resigns from office, the Association refers back to the Parliamentary Rules under the Roberts Rules of order for direction.

#### **SECTION 2 PRESIDENT**

- A. This person must have been a member of the Association for a minimum of two years and served in one of the following capacities or a combination thereof: Two years as a Chairperson of an Association committee, two years on the Executive Board, or an Association Officer for at least one year.
- B. The President shall be Chief Executive Officer of the Association, shall preside at all meetings of the Delegates and Executive Board, and shall be an Ex-Officio member, with voting rights, of all committees. He shall be responsible for the enforcement of the By-Laws and rules of the Association and has authority to suspend or expel a member, club or district for violation of these rules.
- C. In the event of a vacancy in the office of President, the Executive Vice President shall fill the office.
- D. The President shall not hold the same office for more than two consecutive terms.

#### **SECTION 3 EXECUTIVE VICE PRESIDENT**

- A. This person must have been a member of the Association for a minimum of two years and served in one of the following capacities or a combination thereof: Two years as Chairperson of an Association Committee or two years on the Executive Board or an Association Officer for at least one year.
- B. In the absence of the President, the Executive Vice President shall perform the duties of the President. He shall perform such other duties as may be prescribed by the President or the Executive Board. He shall be an Ex-Officio member of all committees without voting rights. He shall be responsible for publicity of the Association Queen beyond the usual channels.
- C. In the event of a vacancy in the office of the Executive Vice President, the Executive Board will elect one of the Vice Presidents to fill the office.
- D. The Executive Vice President shall not hold this office for more than two consecutive terms.

#### **SECTION 4 IMMEDIATE PAST PRESIDENT**

- A. Have served as the President, preceding the current President.
- B. Furnish his experience and knowledge as a part of the officer's committee to further the cause of the Association.
- C. In the event of a vacancy in this office, it would remain vacant until a new President was elected, making available a new Immediate Past President.
- D. May serve until replaced by a new Immediate Past President.

#### **SECTION 5 REGIONAL VICE PRESIDENT**

- A. This person must have been a member of the Association for at least two years and served in one of the following capacities for at least one year: (1) District Officer (2) an Association Officer (3) Chairperson of an Association Committee or (4) Member of the Executive Board.
- B. The number of Regional Vice Presidents shall be determined by the Executive Board. The duties of each Vice President shall be designated by the Executive Board. (For duties, refer to the Operating Procedures).
- C. Election procedures for Regional Vice Presidents. In the event of a vacancy in one of the offices of Regional Vice President, the Executive Board will elect a successor.
  - 1. The Regional Vice President shall be elected by the two club delegates from each club in that region. A quorum of delegates must be present. This meeting must be held no later than 30 days prior to the Convention. No later than 15 days prior to the election, the Regional Vice President will notify the Association office of the time, place and date of election. The Association office will then mail out election notices to all members. The Regional Vice Presidents will notify the Association no later than 15 days prior to the Convention, the results of the election.
  - 2. In the event of a vacancy in one of the offices of Regional Vice President, the President will appoint an interim Regional Vice President to oversee the business of the region until a region meeting can be held (following procedures outlined in ARTICLE IV, Subsection C above) to elect a new Regional Vice President. The new Regional VP will take office immediately upon notification of the Association office the results of that Region's election. If there are no qualified persons in the Region to assume the office of Regional VP, an Executive Board meeting will be called in order to select a successor to fill the vacancy.
- D. May succeed himself as many times as elected.

- E. Shall represent the Association as Chief Officer within that region.
- F. Have a minimum of 3 regional meetings a year.

#### **SECTION 6 ASSOCIATION QUEEN**

##### **Queen's Program has been tabled until a Candidate is made known. (Convention 2024)**

- A. Refer to Queens Handbook (Revised on October 21<sup>st</sup>, 2023) for more information that is not included in this Association Rulebook.
- B. Queen Contestants must be an unmarried young lady, without children, of the same age as our Intermediate Women's Class.
- C. Queen Contestants must be a paid member in good standing of the American Association of Sheriff Poses & Riding clubs (AASP & RC).
- D. Queen Contestants must have been an active member for at least one year prior to running for the Office.
- E. Because the Queen Contestants will be "Goodwill Ambassadors" of the AASP & RC, they will be expected to conduct themselves accordingly. The Queen Contestants shall consider themselves as candidates who are actively seeking to fill an office and shall make every attempt to participate in all Association functions and meetings.
- F. The Association will host a Queen's Contest Play during Play Day Finals each year. This contest will consist of an interview, a knowledge demonstration (i.e. basic knowledge of horse, saddle, and safety) and a horsemanship pattern.

##### **Expectations/Requirements of the Queen**

- 1. Refer to the Queen's Handbook available as of October 21<sup>st</sup>, 2023.

##### **Expectations/Requirements of the Association**

- 1. Refer to the Queen's Handbook available as of October 21<sup>st</sup>, 2023
- 2. The Queen will NOT be furnished a trailer, scholarship, or other compensation, as serving in this office will be strictly voluntary.

##### **Judging Procedures**

- 1. Refer to the Queen's Handbook available as of October 21<sup>st</sup>, 2023

## AASP & RC Queen's Contest

APPLICATION FOR AASP&RC QUEEN  
*This form must be submitted to the Queen's Advisor  
and postmarked no later than May 1st.  
The Queen will reign from Convention to Convention*

Applicant's Name: \_\_\_\_\_

Street Address: \_\_\_\_\_

City, State, Zip: \_\_\_\_\_

Mobile Phone: \_\_\_\_\_

Home Phone: \_\_\_\_\_

Region #: \_\_\_\_\_ District #: \_\_\_\_\_

Home Club: \_\_\_\_\_

Emergency Contact: \_\_\_\_\_

Emergency Contact's Phone: \_\_\_\_\_

**\*\*\*\*\*By signing below, I hereby acknowledge receipt of a  
copy of the Queen's Contest Rules and Requirements,  
and I agree with them as stated.\*\*\*\*\***

Signature: \_\_\_\_\_

Date: \_\_\_\_\_

## **ARTICLE V – AUDITING, BONDS, MONIES**

### **SECTION 1 AUDITING**

The Association shall conduct its affairs on a calendar year basis, beginning January 1st and ending on the last day of December. The Treasurer shall submit an itemized statement of income and expenditures at the annual meeting of the Delegates. The Association books and records must be audited at the end of each fiscal quarter of the current year by an Audit Committee and the officers must approve the report.

### **SECTION 2 SURETY BONDS**

The Treasurer, and all other officers, employees and Concession chairperson of the Association shall be covered by a Blanket Fidelity Bond supplied by the Association for the faithful discharge of his/her duties. The President must bond these officers and employees in the amount of (\$40,000.00) before they take office.

### **SECTION 3 MONIES AND ACCOUNTS**

The Association Accountant is to provide financial services to the Association at a maximum charge of \$50 per month unless authorized by the Officers to exceed that amount. The accountant will prepare the monthly financial reports, prepare P&L reports on various functions as requested and produce other such financial reports as requested by the President and Executive Board. This service excludes the yearly tax preparation fees. At the end of the fiscal year, any Club, or member thereof, or a District, owing a past due account to the Association, shall be suspended until this account is settled.

## **ARTICLE VI – STANDING COMMITTEES**

### **SECTION 1 COMMITTEE MEMBERSHIP**

The chairperson of each committee shall be appointed by the President and be a member in good standing for a minimum of one year. The Chairperson's term ends at the annual Convention no matter at what time they are appointed during the year. This "term" shall constitute a year of service. Committee Chairs may appoint as many members to their committees as they see fit.

### **SECTION 2 COMMITTEES**

#### **A. All Breed Horseshow - SUSPENDED DURING 2011 CONVENTION**

#### **B. Nominating committee**

1. This committee shall make the nominations for the Association Officers.
2. The first meeting of the nominating committee shall be held at Playday finals each year.
3. At this meeting, the members of the committee shall submit the names of persons recommended for each office.
4. These selections shall be based on the person's ability, and each candidate must meet the minimum requirement for his respective office as specified in Article IV of these By-Laws.
5. The recommendations of this committee shall be announced in the Riders Roundup.
6. Any member club may submit a nominee for any office to the committee.
7. The final report of this committee shall be submitted to the Delegates at the Convention and no more than three (3) persons shall be submitted for any office by this committee.
8. The floor may be opened for nominations by a motion and a second, and shall be for each office separately. All nominees must meet the minimum requirements as set forth in Article IV at the time of nomination.
9. All elected officers must be elected by a majority of greater than 50%.
10. In order to be nominated for an executive office at Convention, nominee must be in attendance at said Convention.

#### **C. Awards**

Responsible for recommending and presenting to the officers all awards including the number of places for Playday finals.

**D. Concession Stand**

Check concession stand equipment for repairs and improvements needed. Operate, stock, coordinate, and supervise the operation of Concession Stand for all Association Functions.

**E. Barns**

Responsible for making sure all stalls sold are properly transferred. Report all damages to the officers and to the stall owners for repair. Schedules stall rentals for all Association Functions.

**F. Electrical**

Recommend needed repairs and improvements to the Officers of all electrical equipment.

**G. Grounds**

Duties are to recommend all repairs and improvements needed to the Officers.

**H. Water & Sewer**

Duties are to recommend all repairs and improvements needed to the Officers.

**I. Parade**

This committee is charged with the responsibility of recommending the rules for the Parade activities of the Association. All rules recommended by this committee shall be presented to the Executive Board for final approval and clarification.

**J. Rules**

This committee is charged with the responsibility of recommending the rules for the Playday activities of the Association. All rules recommended by this committee shall be presented to the Executive Board for final approval and clarification.

**K. Promotional**

This committee is charged with the responsibility of promoting the Association.

1. To organize and publicize the use of the facility at Bowie to generate income.
2. To see that all Memorial Donations are acknowledged, reported to the family, and recognized in the Riders Roundup.

**L. Princess**

**M. Scrapbook**

The Scrapbook Committee makes recommendations to the officers for scrapbook awards.

**N. Youth**

Organize activities for the youth at Playday finals.

**O. Audit**

The President appoints an Audit Committee with the approval of the officers.

**P. Scholarship**

This committee and scholarship award monies will be suspended for 2017. Responsible for publishing Scholarship Applications in Riders Round-Up and forming a review committee to judge applications.

**Q. Playday Finals**

Responsible for ensuring safe arena ground conditions and game setup including all game equipment, timers and PA's

**R. Queen**

The Queen contest resumed in 2018. The Queen will be with title only. She may represent this Association wherever she wants to ride and the Association will provide a sash and a crown. The crown will be passed down to the next queen. The crown and sash will be provided by sponsorships and/or donations and will not cause the Association to incur any expense. See Article IV, Section 7 Association Queen.

**SECTION 3 QUORUM**

The number of members attending committee meetings shall constitute a quorum.

**SECTION 4 CREDENTIALS**

All members of each standing committee, who are not properly registered on the records in the Association office, shall submit to the chairperson a letter of certification of voting privileges, signed by at least two officers of the District which he represents.

#### SECTION 5 SPECIAL COMMITTEE

The President, or the Executive Board, may create and empower other committees as they deem advisable.

#### SECTION 6 EXECUTIVE BOARD

**A. How constituted.** Thereby created an Executive Board consisting of: (1) current officers, (2) one representative elected by each district, (3) the chairperson of each standing committee.

1. The President may appoint additional members as needed for the betterment of the Association; but may never appoint more than six (6) members.
2. The elected members of the Board may, from time to time, change the number of appointed members.
3. To be appointed to the Executive Board, a person must have been a member in good standing within the Association for a minimum of two (2) years.

#### **B. Duties and Powers**

1. When a meeting of the Delegates is not in session, the Executive Board shall have, and exercise, all the duties and powers vested in the Delegates by these By-Laws
2. Members of the Board shall have the right to vote in the meetings of the Delegates.
3. The Executive Board shall have the right to remove from office any Association or District officer.
4. The Executive Board shall have the power to place on probation, suspend, or expel a District or a member club.
5. The Executive Board or a District shall have the power to suspend or bar an individual from Association activities.

#### **C. Meetings**

1. The Executive Board shall hold a minimum of two (2) regular meetings each year.
2. At the first meeting of the year, the Executive Board shall require a budget for the year, which has been approved and recommended by the officers, to be presented to the Executive Board. At each meeting, the Board shall review the budget, as well as a financial statement.
3. The Board shall, at each meeting, ratify or rescind all actions of the officers since the previous Executive Board meeting.
4. The Executive Board shall meet whenever and wherever called by the direction of the President or twenty percent (20%) of the Board acting jointly.
5. In the event of a called meeting, the President shall give ten (10) days written notice to each member and, upon being notified of a called meeting by the President or twenty percent (20%) of the Board acting jointly, he shall process via mailed, fax, email such notices within forty-eight (48) hours.
6. The Executive Board meetings shall be open, but only members of the Board may vote or present proposals. Any club member, other than an Executive Board member, who wishes a proposal presented, must submit it to his respective Executive Board member prior to the meeting.
7. The Board may act by written ballot, without convening in meeting. The term written ballot may consist of response via US Mail, fax or email.
8. At any meeting of the officers or the Executive Board, the Chairperson shall take, or cause to be taken, the minutes of such meeting. In addition, he shall record on tape, or cause to be recorded on tape, the entire proceedings of such meeting and such tapes shall be filed in the Association office as a permanent record and kept for a period of three (3) years. Language used in such meetings should be such that tapes could be played back in mixed groups without fear of embarrassment to anyone.

### ARTICLE VII – OPERATING PROCEDURES

**A. Operating Procedures** There shall be attached to these By-Laws, a list of "Operating Procedures" as established by the Executive Board. These Procedures may be changed by the Board as long as they do not conflict with these By-Laws.

#### SECTION 1 DUTIES OF OFFICERS

**A.** May hold an office at the District or Club level at the same time as holding an Association Office.

- B. Represent the entire Association, not a District, Club, or an individual. Dedication should be for the betterment of the entire Association.
- C. The major projects accepted are his responsibility to carry out in their entire scope; including bringing up new ideas for the betterment of these projects.
- D. All decisions of policy making and policy changes must be approved by the Executive Board.
- E. Should use caution in making direct decisions unless the answers are known from past established policy.
- F. Officers and their families, when accompanying them, may participate, and qualify, for AASP&RC competition within their domain: Vice President in his region, President, Executive Vice President, Treasurer, Immediate Past President, AASP&RC Queen in all regions. Special privileges are granted to Princesses (candidates for AASP&RC Queen) to compete and qualify in any district in their respective Region.
- G. Duties of President - See Article IV, Section 2.
- H. Duties of Executive Vice President - See Article IV, Section 3
- I. Duties of Treasurer- See Article IV, Section 4.
- J. Duties of Immediate Past President - See Article IV Section 5.
- K. Duties of Vice President- See Article IV, Section 6:
  1. Represent the Association in his region as though he/she were President of the AASP&RC.
  2. Assist in setting up new clubs and districts, and promote the Association in every contact. Investigate, recommend, or reject new clubs.
  3. Copies of all correspondence pertaining to Association projects should go, not only to the President and Executive Vice President, but also to all Officers, to keep them informed of these projects.

#### **SECTION 2 QUARTERLY OFFICERS MEETINGS**

The Officers of the Association shall meet at least quarterly. The duties and powers of the officers at these meeting shall be:

1. Approve report of the President pertaining to ordinary business operations of the Association, and implementation of established policies and programs to be carried out by the President and reported to the officers.
2. Necessary adjustment of established policy recommended by the President may be approved by the Officers and reported to the Executive Board.
3. New programs. Consistent with established policy, may be considered and acted upon by the Officers and reported to the Executive Board with recommendations. Such programs, upon Approval by the officers, may be set in motion when delay would not be in the best interest of The Association. Such actions should be understood to be pending Executive Board approval.
4. Questions concerning procedures involving, or problems normally considered a function of, one of the Association Standing Committees, should be referred to the appropriate Committee Chairperson and not considered by the officers, unless, in their meeting, prompt action is deemed necessary, or unless the problem is referred to the officers by the Committee Chairperson involved. Questions concerning the Queen's contest should be referred to the President or Queen's Chairperson.

#### **SECTION 3 COMMITTEES**

##### **A. Standing Committees**

1. All standing committees shall meet at least once each year, preferably at their Association Final competition. Each committee, keeping in mind the recommendations of the Delegates at the Convention, shall take any action for the betterment of its respective activity at this Meeting, and submit their recommendations to the Executive Board.
2. Each committee shall have its own secretary to handle the minutes of the meeting, turning them over to the Association Office for filing and necessary mailing.

##### **B. Special Committees (refer to Article VI, Section 5)**

1. Credentials Committee: There shall be a Credentials Committee appointed by the President. This committee shall check the certification of each delegate and committee member at each Meeting.

#### **SECTION 4 ASSOCIATION SPONSORED FUNCTIONS**

## **A. Responsibilities of Association**

All Association Functions shall be under the sponsorship of the Association Office and Officers Committee.

1. The Association shall assume full financial responsibility of the Association Sponsored Functions, assuming any loss/profit from such. Fees for all functions shall be set by the Officers Committee. There will be no refunds of fees to members. All Association functions and meetings will be held on the 3rd weekend of said month.
2. Any member of the Association, who attends and participates in any of the functions, will be required to pay the General Registration Fee, set by the Officers Committee.
3. The Association office is authorized to project site selection for the Association Sponsored Functions into the future as may be advantageous, with the right of final approval of the selection of site by the Officers Committee.
4. Host: The Association Office shall work through and with a host organization whenever possible in making local arrangements.
5. Officers Uniform: White Long Sleeved Shirt, Natural Straw Hat (summer), Silver Hat (winter), Dark Blue Jeans, Officer Buckle and winter jacket. The President shall designate the Association Functions at which the Officers/Past Officers wear The Association Uniform. The Officers are allowed to select a Summer Uniform. The Association will supply an Officer Buckle for the Officers.

## **B. Convention**

Club delegates have business meetings in which they evaluate the policies for the past year, set policies for the next year and elect officers. This function is primarily for adult members of the family, and includes informative meetings, social activities, judging for club scrapbooks, presentation of annual awards, and crowning of the Association Queen.

1. All members of affiliated clubs are urged to attend this annual event. Each club is responsible for having two voting delegates in attendance.
2. Awards
  - a. Scrapbook award and certificates, 1st, 2nd, 3rd. Junior, Novice and Senior Divisions. Novice Divisions 1st place traveling trophy donated by R.E. and Donna Myers. The Senior Division Traveling Trophy will be known as the John Cook Scrapbook Traveling Trophy and is donated by the San Angelo Saddle Club. (See Scrapbook Section.)
  - b. Scrapbook Awards and Certificates, 1st, 2nd and 3rd place. (See Scrapbook Section)
  - c. Convention will be a one (1) day meeting held in Bowie, Texas with no lunch provided; there will be 2 hour lunch break for attendees to secure their own lunch.
  - d. Cost of convention will be \$25.00 for voting rights ONLY

## **C. Spring Roundup - March 18, 2023**

1. Spring Roundup and Save A Life will be a combined event on the 3rd weekend in April with a 75/25 split with the 25% split being 15% going to the AASPRC and 10% going to the two charities.
2. All office fees, exhibitions and the playday proceeds goes back to the association.
3. There will be a back-up clock at Spring Roundup.
4. Registrants participate in various phases of Association activities at the Spring Roundup: trail rides, arena games, dinner and dance, etc. Fun for the whole family.
5. Scoring of points. Points to determine individual class winners will be as follows: 10 points for 1st down to 1 point for 10th. (If only 6 places are given, 1st will get 6 points and 6th will receive 1 point. Number of points may not exceed the number of riders in the class or event.) Number of high point placings will be at the discretion of the SRU Committee.
6. Awards
  - a. Awards for Arena Games.
  - b. A traveling trophy in memory of Robert D. "Pop" Garvin awarded to the oldest Trail rider at Spring Roundup.
  - c. Youngest Trail rider.
  - d. Best equipped Trail rider.

- D. As of 2018 Spring Roundup Format:** Open Jackpot Playday, \$5.00 per event, 75% payback, combined classes, Payout: 1-3 riders, 2 places, 4 to 8 riders, 3 places, 9 riders and over 4 places.

#### **SECTION 5 REGION**

The Association is divided into regions for a more balanced organization and for competition.

- A.** A Regional Vice President shall be elected by the Club Delegates within that Region to represent the Association as the Chief Officer in his/her Region.
- B.** Two delegates from each club, and the Executive Board member from each district, shall run the business of the region.
- C.** Regional governing boards should follow those guidelines now set up for districts in this manual.
- D.** The districts in a region may be transferred from time to time to make these adjustments. The region and districts within each region are:
  - Region 1 West Texas - Districts 1 & 2
  - Region 2 Bowie & North Texas - Districts 12 & 31
  - Region 3 Ft. Worth & Central Texas - Districts 17, 24, 25 & 29
  - Region 5 Dallas & Southeast Texas – District 14 & 22
  - Region 6 Southwest Texas - Districts 4 & 5
  - Region 7 South Texas - Districts 6, 8 & 10

#### **SECTION 6 DISTRICTS**

- A.** Each region is divided into districts for members' convenience and for the development of the Association.
- B.** The Posse or Club designated shall be headquarters for the district, but the Officers of the district may do business at any place convenient to the members or officers.
- C.** The following officers are elected at the district level: President, Vice President, Secretary, Treasurer and Standing Committeemen, (Refer to Article VI and Operating Procedures. Section 3). These, plus the delegates, two from each club, shall direct all policies and activities of the District.
- D.** All Districts shall elect officers before the Convention.
- E.** Qualifications for forming a new district:
  - 1.** Group of clubs wishing to form a District should contact the Association Office or the Vice President of their Region.
  - 2.** Minimum of two (2) clubs.
  - 3.** Minimum of ten (10) family memberships in each of these two clubs.
  - 4.** Districts may add additional clubs with fewer members provided the district has met the above requirements.
  - 5.** District By-Laws shall not be in conflict with the By-Laws of the Association.
  - 6.** The President may authorize the District on a temporary basis, for a period of one (1) year.
  - 7.** The District does not have voting delegates at the Convention nor does the District pay a membership fee to the Association.
  - 8.** For a new or re-activated district or club to have voting privileges at that year's convention, they must have made an application to or submitted a written request for re-activation in the Association office no later than April 30th and have representation from that district and club at American Association finals that year.
  - 9.** An existing district may petition the Association to change regions upon meeting the following requirements:
    - (1) The district request and receive an approval letter from all member clubs in that district to be signed by the officers of the member clubs,
    - (2) The District request and receive an approval from both Region VPs involved and
    - (3) They submit the request citing the reasons for that request along with the aforementioned approval letters to the Association office for consideration. Once these qualifications have been met, the President will contact all Executive Officers and vote on the request. If the request is approved by a majority of the Executive Officers, the club affiliation will be transferred to the new District at that time.
- F.** Activities
  - 1.** Sanctioned District Activities - Queen Contest and all approved games and activities.
  - 2.** Suggested Activities - District may raise money to finance activities and awards by charging a District membership fee, entry fees at Playdays and other fundraising projects. Social activities in addition to horseback functions will create additional interest in the District.

3. Anyone who participates in any district point playday must be an AASP&RC member in good standing. Violation of this rule is covered under II President Article IV Section 2, Paragraph B.

#### SECTION 7 CLUBS

- A. The member club of the AASP&RC is the grass roots stockholder of the Association.
- B. Delegates: The two (2) Delegates from each club meet each year at the annual Convention to review the past, establish policies for the future, and elect Association Officers for the coming year.
- C. Headquarters: The clubhouse is usually the headquarters for the club. In some cases, however, a club uses a municipal building for meetings and only has a post office box as an address for the club.
- D. Officers: The locality and activities of a club govern the duties and names of the offices. The leader being called Captain or President is unimportant. It is suggested that each club consider patterning their committees, using the Association committees as guidelines. The club voice to the District and the Association is through their (2) delegates.
- E. Activities: The club is the basis for all legislation and competition in the Association. In most cases, clubs contest against each other at the district level, and then combine their efforts to compete against other districts. The individual, regardless of the level of competition, never loses his/her identity with the club. Exception: A club is authorized to add associate members from another club without paying additional Association dues. This provision was originally made to encourage competition in team events and permit contestants to find team mates through this associate membership in an additional club where it was impossible in his/her club. In order to participate as a member of any club other than his/her home club, a person must have met all requirements and must have been accepted into the second club as a club associate member by the same standards as regular members of that club are accepted and maintained. The membership of the second club must include the associate club members on the records of that club in the Association Office before he can compete in Association sanctioned activities as an associate club member. NOTE: This not to supersede the By-Laws of a local club. NOTE: All team events- have been discontinued.
- F. If a club has not been in good standing with no members joining the association within 2 consecutive years, the club will be dropped from the association roster.

#### SECTION 8 GENERAL RULES

- A. No person shall cause to be administered internally or externally to a horse, either before or during an approved event, any medication or drug which is of such character as could affect its performance, and upon discovery of the administration of such drug or medication, the management shall immediately disqualify the rider and report the matter in writing to the Association Office for disciplinary action.
- B. Horse or rider shall have no unnatural or artificial equipment such as hot shots or buzzers or any other items not normally used in Western Riding. It is a disqualification for that function only (using an electrical device)
- C. Rules of Conduct: Any act violating the Texas Penal code will be cause for disqualification. This rule shall be implemented by a majority vote of officers at that activity. A written report will be filed with the Association office.
- D. Any letter, whether unsigned or not, criticizing Association or members, must go to officers to decide if it will be published in the Riders Roundup.
- E. Equipment: Western Equipment is compulsory. Example: No bareback riggings or pads. Barrel race saddles built on western stock saddle type will be permitted. Exception: Protective gear or the uniform of drill teams,
- F. Unmanageable horse: Judges may disqualify an unmanageable horse for reason of safety.
- G. All business meetings will be conducted as per Robert's Rules of Order.
- H. Age Divisions: the individual age as of January 1st.
- 58 and over Classic Seniors
  - 45 thru 57 Super Seniors
  - 25 thru 44 Senior
  - 16 thru 24 Intermediate
  - 11 thru 15 Junior
  - 7 thru 10 Pee Wee
  - 0 thru 6 Super Pee Wee

Each division is divided by sex. NOTE: These age groups may be combined by order of the Executive Board with the exception of Playday Finals.

- I. Stalls: Built and/or purchased by member families of the AASP&RC may be used by that member or members of his/her family as long as the member or family member is pre-registered for the event and is a member in good standing with the AASP&RC. Stall owners may sell their stalls to Association members or to the Association for no more than the original cost. A stall owner must be inactive in the Association for two years before the Association can assume ownership of stalls. Association stalls are not for sale. Association stalls may be exchanged for privately owned stalls. All trades must be approved by the Association President upon the following conditions.
  - 1. Stall must be in good repair and approved
  - 2. Ten dollar per stall office fee;
- J. Stall owners shall be notified of necessary repairs and if after notification these repairs go unmade after 45 days, the Association will repair said stalls and the stall owner will be billed for the repairs.
- K. No Wire Pens. Panel Use Only, No T posts or electric fencing on grounds.
- L. No horses allowed in the RV area.
- M. Association Clubs, Districts, and Regions may use the grounds at no charge. The Region VP from that club or district will be in charge of assuring that the grounds are cleaned and any damage done to the Association grounds will be paid by the Club, District or Region.
- N. All contestants' riding attire is the responsibility of the rider; however, for safety reasons, the AASP & RC recommends heeled riding shoes, jeans, and a suitable shirt.
- O. No attachments can be built or added to stalls or barn areas. No expansion of stalls or shade barriers which cause obstruction in common areas. If a member has a mare with a colt under five months old, the member is allowed to put a ten foot panel extension on stall for mare and colt during an Association function. Mare/colt stall modifications only in less traffic areas and members must alert Association to situation when registering.
- P. The 50/50 Challenge with the NARC&SP will be an official function of the AASP&RC.
- Q. RV Spot – The FEE to secure “First right of Refusal” which would guarantee first right of refusal at all association functions is... 5 years - \$150.00, and 10 years - \$250.00.

## **ARTICLE VIII AMENDMENTS**

### **SECTION 1- MAKE, AMEND & REPEAL**

The delegates shall have the power to make, amend and repeal the By-Laws of the Association by vote of a majority of the Delegates present at any regular or special meeting of the delegates.

### **SECTION 2- EMERGENCY**

In the event of an emergency, the Executive Board, by two thirds vote, may make a by-law change effective immediately, but such an amendment may be rescinded at the next meeting of the delegates. Any such by-law change shall be done by written ballot.

### **SECTION 3-ABEYANCE**

All amendments to the by-laws of this Association made by the Executive Board shall be held in Abeyance until the next meeting of the delegates.

### **SECTION 4-CHANGES DISTRIBUTED**

All such changes made by the Executive Board shall be published and distributed to the members at least thirty days prior to the next meeting of the delegates.



**APPLICATION FOR MEMBERSHIP**

**THE AMERICAN ASSOCIATION OF SHERIFF POSSES AND RIDING CLUBS**

Name of Posse or Club \_\_\_\_\_

Address \_\_\_\_\_

Town \_\_\_\_\_ State \_\_\_\_\_ Zip \_\_\_\_\_

Membership in District # \_\_\_\_\_ desired

Officers of the above club asking for membership (Use other side if necessary)

1. Name \_\_\_\_\_

Office \_\_\_\_\_ Phone \_\_\_\_\_

Address \_\_\_\_\_

2. Name \_\_\_\_\_

Office \_\_\_\_\_ Phone \_\_\_\_\_

Address \_\_\_\_\_

3. Name \_\_\_\_\_

Office \_\_\_\_\_ Phone \_\_\_\_\_

Address \_\_\_\_\_

4. Name \_\_\_\_\_

Office \_\_\_\_\_ Phone \_\_\_\_\_

Address \_\_\_\_\_

5. Name \_\_\_\_\_

Office \_\_\_\_\_ Phone \_\_\_\_\_

Address \_\_\_\_\_

6. Name \_\_\_\_\_

Office \_\_\_\_\_ Phone \_\_\_\_\_

Address \_\_\_\_\_

Delegates: These two people vote, representing your club at the District and Association level.

1. Name \_\_\_\_\_

Office \_\_\_\_\_ Phone \_\_\_\_\_

Address \_\_\_\_\_

2. Name \_\_\_\_\_

Office \_\_\_\_\_ Phone \_\_\_\_\_

Address \_\_\_\_\_

We understand the purpose of the AASP&RC is to encourage the motto of "Horsemanship, Sportsmanship and Citizenship" and to keep alive "The Spirit of the Old West". We have read and understand the By-Laws of the AASP&RC.

We shall help the Association promote the acquaintance and friendship among its members through promotion and participation in Parades, Playdays, Horse Shows, and other activities related to mounted sports.

We, as a club, understand that the Association makes no effort to dictate our policies, however, our By-Laws and practices are not to be in conflict with the By-Laws of the AASP&RC.

---

\_\_\_\_\_  
Signature of Officer of club making application for membership

Recommendation of a District President and Regional Vice President

Approved \_\_\_\_\_ Disapproved \_\_\_\_\_

\_\_\_\_\_  
Signature of District President

Approved \_\_\_\_\_ Disapproved \_\_\_\_\_

\_\_\_\_\_  
Signature of Regional Vice President

## PARADES

### Section 1 - Purpose

The AASP&RC in 1952 was originally organized for the purpose of standardizing parade judging forms and this is still one of our objectives.

There has been much time and many hours of discussion giving us the following rules for judging parades. The purpose now, as it was then, is to give each parading group an opportunity to know the points that will be observed as they parade, giving them an opportunity to be prepared, and the judges a definite point value, as to what each club deserves.

Parade judging forms are available at the Association office upon request. They are also available for nonmembers of the Association.

Parade groups may earn points toward championship by participation in sanctioned parades.

### Section 2 - Specifications for Sanctioned Parades

- A. Request by the sponsoring organization for parade judging forms.
- B. Minimum of three (3) judges. Judges should be selected early enough so that they may familiarize themselves with the rules as set forth. Insist that each judge by these rules and not be influenced by anyone or anything else. Each judge must sign his/her judging form.
- C. Parade must be open to all Association member clubs in good standing.
- D. At least one member of the parade group must be a member in good standing with the Association.
- E. If only one group is parading, they can still be judged and their points counted, if it is judged by the AASP & RC rules.
- F. Furnish each judge with a judging form and parade order of each riding club. The office is to send a completed example of a judging form to each organization who requests forms for sanctioned parades.
- G. All judging forms that were used, not just the winners, must be returned to the designated address of the Association office for permanent filing. These records are the method by which points are given toward accumulation for an annual award. Individual names of the parade participants must be listed on the back of the parade form.
- H. If you wish to judge juniors and seniors separately, a junior club is one with no more than three (3) adults riding in it. Junior riders will be 17 years old and under.
- I. For safety reasons, any unruly horse in a parade group could disqualify or cause loss of points for the entire group.

### Section 3 - Qualifications for Championship

- A. Results of parades sent in on Parade Report Form by participating clubs within 30 days after parade date. Points for parade participation should be turned in at least 30 days prior to the Convention for yearend awards.
- B. Clippings from newspapers sent in when available.
- C. Points earned in sanctioned parades are as follows: 1st-- 10 points, 2nd-- 6 points, 3rd-- 4 points. Points are accumulated throughout the year at sanctioned parades.
- D. Awards Presented at Convention.
  - 1. Parade, Senior Division, 1st, 2nd, place awards.
  - 2. Parade, Junior Division, 1st, 2nd place awards.
  - 3. The Grady Munden Memorial Award, a traveling trophy, is presented each year to the first place junior parade group.
- E. A riders' roster must be turned in with the report form to assure that at least one of the riders is an AASP&RC member.

### Section 4 Parade Guidelines

Explanation of Judging Forms: There are four phases of judging. The first three are a simple mathematical process and the fourth is a matter of judging each group as to the behavior of horses and riders, spacing of participants, and general appeal and attractiveness of the overall group. The winners will be determined by the total points earned in the four phases of judging. The highest total number of points will be the winner, next high, second, etc.

### **Uniformity of Horses**

1-10 Bonus points are given for generally matching size and color of horses within the group.

### **Grooming of Horses**

Subtract 1 Point per Horse for not being properly groomed (Clean, Brushed and Trimmed, Feet, Body, Mane and Tail)

### **Uniforms**

Subtract 1 Point for each horse and/or rider out of uniform.

### **Judges Decision**

1-25 points - Poise, Precision and Showmanship - Each Judge will judge the group as impressed with the good and bad features of the group. Judges form will provide for a 10 point bonus for grooming with a subtraction of points for horses not properly groomed and dressed.

## **Section 5 Parade Ethics**

### **A. Flags**

1. American Flag takes precedence over all other flags
2. State flags take precedence over all club flags.
3. The American flag should always be on the right, state flag on the left when carried together.
4. State flags should be carried on the right and club flags on the left when carried together.
5. The American flag should lead, State next and club next in that order when carried single file.
6. The American flag should always lead a parade with the lesser flags behind it. In some cases it has been permitted for each Posse or Club to carry their own American flag at the head of their unit, but it is not considered the best ethic.
7. It is general practice for Association flags in parades to lead the parade behind the American and State flags or in front of the first mounted group.
8. All persons carrying flags, other than the American flag, should lower the tips of their flags in respect to the National Anthem.
9. It is not necessary for riders carrying flags to remove their hats during the playing of the National Anthem.

### **B. Association Officers**

1. Since Association Officers are representing our entire Association, they should have a place of honor before any riding group in a parade or grand entry.

### **C. Parade Ethics: Suggested Protocol for Parade lineup.**

1. President or Queen
2. When the Queen is placed in double file with the President, she shall ride to this left, when she is double file with an Officer, she shall ride on his/her right.
3. Regional Princesses.
4. Elected Officers.
5. Regional Officers.

### **D. Riding in a Parade**

1. Try to look as though you are parading and not riding the range in your most comfortable, slouchy position. It does not make you look like a cowboy, but only detracts from the parade as a whole.
2. Ride straight in the saddle, holding your reins as though you could control your horse if the need arose.
3. Hold a flag straight so people can see it and not lay it down as though you were about to drop it.
4. Stay in line and watch your spacing from other horses. The rider on the right is responsible for keeping the space from the other horse in front and staying in line. The rider on the left dresses off him, and keeps his horse in line with riders in front of him/her.
5. Execute your turns in parade fashion. Don't cut across so you will not have to ride so far. If pivot turns are ordered by your Marshall, execute them correctly, if criss-cross, then do them as prescribed.
6. Only one rider per horse.
7. Children may be led and points will not be counted off. They should be at the back of the parade group.

### **E. Parade Marshals.**

1. Be sure dignitaries and invited groups are met and told what position is reserved for them. Don't leave them standing around wondering if you really knew they were invited. This is most distressing on the person you have invited, and shows very bad planning or bad manners on the part of the host club.
2. Prepare a list of people riding in the parade and see that they are introduced as they ride by the judges' stand, or other places where you have loud speakers. Get their name and organization correct. Calling someone by a wrong name is worse than not calling it at all. Be sure your announcer has the name and organization correct. This is all very important to your clubs and town. Bad mistakes reflect on the host Club and everyone connected with it.

**F. Grand Entry**

1. Brief the announcer early on who is to be introduced and prepare a list for him. A spotter also helps even if you have a list, because your rodeo announcer is usually a stranger and does not know the procedure or people.
2. You, as Sponsor, are the boss. You are paying the Rodeo Producer or Stock Contractor to furnish the stock or produce the rodeo, and he is supposed to do as you wish. This should be understood before you hire him.
3. Association officials who ride in your parade and grand entry should also be introduced, not so much for the person, as for the Association. It is your Association and the more it is brought before the people, the more help it will be to your future Rodeos and Parades.

**Section 6 Officials**

- A.** Minimum of three (3) judges. (One additional person may be used to determine the adjusted number of each riding group.)
- B.** Judges should be familiar with judging forms.
- C.** Judges' discretion should be used to determine in which type the group belongs.
- D.** Complete the first three phases of your judging, if possible, before the parade begins. However, do not hesitate to change your figures if you find them to be incorrect at any time, (Some may arrive late or some may improve after you have inspected them)
- E.** Be accurate. If time does not permit completion of the first three phases of the judging forms before the parade, have parade groups return to the forming area for completion of judging.
- F.** Place judges in advantageous positions to judge the parade. If there is a "Spooky" place on the parade route, let one judge see all of the groups pass it, one should see them on the straight, etc. Don't change positions; judge them all under the same conditions. This means you will likely show different scores, but it will give you complete coverage, likely showing weaknesses and strengths of each club.
- G.** Judging schools or instructions are available upon request at the Association Office.
- H.** If desired, each judge may be assigned only one section to judge instead of all judges judging all sections, but all judges should be responsible for overseeing the compiling of points.

## CLUB PARADE REPORT FORM

American Association of Sheriff Poses and Riding Clubs  
Reporting sheet for Association Sanctioned Parades

\_\_\_\_\_SR – JR \_\_\_\_\_

CLUB \_\_\_\_\_

CITY \_\_\_\_\_ STATE \_\_\_\_\_

PRESIDENT \_\_\_\_\_

Parade held at \_\_\_\_\_

Number of Clubs Participating \_\_\_\_\_

Sponsored by \_\_\_\_\_

1<sup>st</sup> Place \_\_\_\_\_

2<sup>nd</sup> Place \_\_\_\_\_

3<sup>rd</sup> Place \_\_\_\_\_

\_\_\_\_\_  
Signature Club President and Date

List individual names of parade participants on the back of the parade report form. This report must be submitted to the American Association Offices designated address within 30 days after the Parade date.

**PARADE ANNOUNCEMENT FORM**

POSSE OR CLUB NAME \_\_\_\_\_

A MEMBER OF DISTRICT \_\_\_\_\_ REGION \_\_\_\_\_

**THE AMERICAN ASSOCIATION OF SHERIFF POSSES AND RIDING CLUBS**

PRESIDENT \_\_\_\_\_

VICE-PRESIDENT \_\_\_\_\_

SECRETARY/TREASURER \_\_\_\_\_

QUEEN/SWEETHEART/OTHER \_\_\_\_\_

PRINCESS/JR. SWEETHEART/OTHER \_\_\_\_\_

OTHER DIGNITARY \_\_\_\_\_

OTHER DIGNITARY \_\_\_\_\_

OTHER INFORMATION/ACTIVITIES ETC:

\_\_\_\_\_  
\_\_\_\_\_  
\_\_\_\_\_  
\_\_\_\_\_  
\_\_\_\_\_  
\_\_\_\_\_

MAILING ADDRESS \_\_\_\_\_

CONTACT PERSON \_\_\_\_\_ PHONE \_\_\_\_\_

## SCRAPBOOK

The Scrapbook furnishes evidence of the activities during the year that let the club be judged as to the "Best all Around Club" in the Association.

- A. Size: Any size is acceptable including multimedia scrapbooks.
- B. Cover: Front Cover and overall appearance
  - 1. Name of Club
  - 2. District
  - 3. City and State-if the club name is in the name of the town, drop the name of the town and "Texas".
  - 4. Year
- C. Contents Inside Front Cover
  - 1. Theme carried out throughout the book.
  - 2. Table of Contents (Pages Numbered) 5pts.
  - 3. Copy of Club By-laws. 5pts.
- D. Categories included in the Scrapbook are to be individual and will run from Convention to Convention.
  - 1. Club History & Activities 10pts.
    - a. Benefit to community 10pts.
    - b. Benefit to members 10pts.
    - c. Special projects 5pts.
  - 2. District participation 10pts.
  - 3. Region participation 10pts.
  - 4. Association participation 10pts.
    - a. Convention 5pts.
    - b. Spring Roundup 5pts.
    - c. Playday Finals 5pts.
    - d. 50/50 5pts.
    - e. Horse Show Finals 5pts.

## REVIEW

**Presentation of Scrapbooks to be at Convention, with a 15 minute time limit for each.**

### Score Sheet and Judges

Entry forms or intentions to present a scrapbook are to be sent in 30 days prior to convention. The Judges must sign their sheet by name and district. After scrapbook entries have met the deadline, they will be judged. If a club enters a scrapbook, no member of the club can judge the class their book is entered in, but could be a judge in another class. The Scrapbook Chairperson is responsible for the judging score sheets, collecting and counting them.

### Divisions and Awards

- A. Senior Division:** The Senior Division Traveling Trophy is donated by Region 7 in honor of Bill and Addie Renfro.
- B. Junior Division:** A book to be composed by members of the club 17 years and under. There will be 1st, 2nd and 3rd place awards in each division in conjunction with the traveling trophies. Traveling trophies are to be displayed at the Association Office.

The scrapbook Chairperson is to send letters to each club president and put notices in the Rider Roundup and follow up letters, including name, addresses and phone numbers of the past Chairpersons to be contacted for advice on Scrapbooks. This is to be after the Convention, with a quarterly follow up letter to the Riders Roundup. Also recommend any club wishing to enter a scrapbook keep all articles and pictures.

Scrapbook may be submitted by Clubs, with notification to Scrapbook Chairperson 30 days prior to Convention, that a scrapbook was being submitted (so they would know which categories they would need awards in).

## PLAYDAY GAMES

The section of Playday Games is to acquaint the membership with the games that have been approved to be run at the Playday Finals and the rules governing them. The playday activities of the AASP&RC are a family affair. In many cases the entire family participates in the competition along with doing the manual labor in the registration booth, concession stand, the announcer's vantage point where the records are kept. This tends to prove that there are many aspects by which the entire family may contribute in many ways to the Association motto of "Horsemanship, Sportsmanship and Citizenship".

The member clubs of the AASP&RC compete at the district level to qualify its contestants to go to the Playday Finals of the Association. These individuals from each club who qualify to represent their district at the Playday Finals compete for individual and district recognition.

Records are of great importance. The Association playday records are kept in the office by the system which accumulates individual points. This enables all contestants to compare times with each other regardless of location of the competition or arena size. Each game has its own formula of adjusting the dimensions according to the size of the arena.

### NEW GAMES

The games to be run at the playday finals will be on a rotating basis starting the 2010 playday season with the exception of poles and barrels. Delegates at the convention can adjust or amend all playday games. Beginning in 2010, the following game rotation will be in effect:

The games are listed with a number. After year one (1) each game at the top of the list will simply drop to the bottom and the rest will move up one spot in the rotation. Each year, we will run the events indicated PLUS Poles and Barrels.

Clover leaf barrels and poles are not part of the rotation as decided at a previous convention. Only the first six (6) on the list are used each year.

#### Year 1 (2019)

1. Spur
2. Bowtie
3. Flags
4. Pylon
5. Straight barrels
6. Flying W
7. Hitch & Go
8. Larryette
9. Baseball

#### Year 2 (2020)

2. Bowtie
3. Flags
4. Pylon
5. Straights
6. Flying W
7. Hitch & Go
8. Larryette
9. Baseball
1. Spur

#### Year 3 (2021)

3. Flags
4. Pylon
5. Straights
6. Flying W
7. Hitch & Go
8. Larryette
9. Baseball
1. Spur
2. Bowtie

Year 4 (2022): 4, 5, 6, 7, 8, 9, 1, 2, 3

Year 5 (2023): 5, 6, 7, 8, 9, 1, poles, barrels

Year 6 (2024): 6, 7, 8, 1, 2, 3

Year 7 (2025): 7, 8, 9, 1, 2, 4

Year 8 (2026): 8, 1, 2, 3, 4, 5

Year 9 (2027): 9, 1, 2, 4, 5, 6

Year 10(2028): 1, 2, 3, 4, 5, 6

In 2019, Spur will go out and Hitch N Go will come in. Spur will move to the bottom of the above list after Baseball. In 2020, Bow Tie will go out and Larryette will come in. Bowtie will move to the bottom of the list after Spur. At Convention 2022, the rotation was amended. Beginning in 2023, Baseball will come in during ODD years and Flags will come in during EVEN years. (These two events will no longer following the rotation schedule noted previously. This rotation will continue until amended by the delegates at Convention.

#### **RULE 1 Description of games.**

Refer to specific games following the rules.

#### **RULE 2 Arena Specifications**

- A. For arena specifications, see arena diagram preceding games
- B. Adjustments for sub-standard arenas - refer to Specific Games.
- C. Starting line will be unmarked.
- D. Any person assisting a playday rider into the arena shall be on foot.
- E. There will be an arena drag every 7 riders (not by names) listed on the time sheets. There will be an arena drag every 5 riders (not by names) during Barrels. Alterations will be at the discretion of the Playday Chair, according to arena and ground conditions.

#### **RULE 3 Equipment**

- A. Refer to specific games.
- B. Equipment shall be handed to the rider after he enters the arena.
- C. Recommended that each district use equipment of the same color as listed-in rule 8 B under Playday Games.

#### **RULE 4 Game Rules**

- A. Age Division: Contestants in the games shall be divided into 14 Classes: Classic Senior Men, Classic Senior Women, Super Senior Men, Super Senior Women, Senior Men, Senior Women, Intermediate Men, Intermediate Women, Junior Boys, Junior Girls, Pee Wee Boys, Pee Wee Girls, Super Pee Wee Boys, Super Pee Wee Girls (refer to Age Division, Article VII Section8-H)
- B. Calls to Ride: Contestants shall be present at the time of call for any event. Three calls will be made; if the contestant is not ready to ride on the third call, he will be disqualified.  
A rider can move up or down within his age group until the end of the age group. If the rider is the last rider, the rider has 5 minutes, in the event of a conflict the rules chairman has the authority to override the 5 minutes to give the rider more time. After that, either ride or be disqualified. Riders can only move up or down with good cause to be determined by the gate judge. If the timer malfunctions, and the rider is at the end of the class, that rider may have 5 minutes to reride. If the rider is peewee or younger, the parent is to make a decision.
- C. Scoring of Points: Points to determine individual winners will be as follows: 10 points for 1st down to 1 point for 10<sup>th</sup>. (If only 6 places were given, 1st place would be 6 points, down to 6<sup>th</sup> place 1 point. Number of points may not exceed the number of contestants in the class or event. 1st through 10th Place should be awarded.
- D. Closed Arena: All games are to be run in a closed arena. The gate must be closed before the rider starts his pattern or before starting forward motion, with a disqualification on the rider if the gate is not closed. The gate should be closed until the rider brings his horse under control after the pattern. No equipment will be handed to the contestant until he is inside the arena. The use of "L" gates (the opening in the arena fence is considered to be the "gate") will be considered a closed arena. Once a rider has completed the event and has his horse under control, another rider may enter the arena.
- E. Horse Rule: A horse may not be ridden but one time in each class or event with the exception of a horse used by an immediate family (Immediate family will include parents or legal guardians and children whether married or unmarried and grandchildren. This also includes sons-in-law or daughters-in-law). Violation will result in disqualification of ineligible riders.
- F. Tie: Single Event: When running off a tie for a single event, a contestant must run within two seconds or less of their original time to win. This rule applies when the runoff time is slower than the original time. If after two unsuccessful efforts, this has not been accomplished, flip of the coin may be used. **Each contestant must use the same horse as in the original contest, unless the horse is unable to be ridden, then the horse rule applies. If a rider's horse is injured and they do not have a second horse, then the coin toss will decide the winner.**

**Tie: Overall Highpoint: When running off a tie for Overall High Point you must ride the original horse that was competed on, unless the horse is injured, then horse rule applies.**

- G.** A family can represent only one district at playday finals.
- H.** Designated people in the arena: No one except those designated by the arena director will be allowed in the arena.
- I.** Time starts and stops when the horse's nose reaches the timer line.
- J.** Striking a horse: A horse may not be struck with playday equipment at any time.
- K.** No physical assistance shall be given past the starting line in any class. Only one assistant per rider may be in the arena during that contestant's ride. Any rider with mental or physical disabilities and/or special needs may be allowed as many assistants as needed past the starting line.

#### **RULE 5 Officials**

##### **A. Announcer:**

- 1.** Number required (1) with assistants.
- 2.** Duties:
  - a.** Call off contestants in the order in which they will run. (Suggestions, call rider by name,
  - b.** Instruct the next one up to be at the gate and the following be ready.
  - c.** Announce the judges' decisions.
  - d.** Announce placing.
  - e.** Keep the event moving.
  - f.** Not talk to excess.

##### **B. Timekeepers**

- 1.** Number required two (2) Back up timekeeper must be a member from a different district than the Primary timekeeper and playday shall not move forward until the backup timekeeper is in place.
- 2.** Equipment: Two electronic timers (to be labeled PRIMARY and SECONDARY) or at least two (2) 100 second stop watches.
- 3.** Duties
  - a.** Make sure the timer is clear before the contestant starts the pattern.
  - b.** Both timekeepers read timer, one calls aloud the time for the announcer and the scorer.
  - c.** Never clear the timer until timekeepers have agreed on the reading.

##### **C. Record**

- 1.** Number required (1) with substitutes.
- 2.** Equipment- Playday worksheets and pencils
- 3.** Duties
  - a.** Record the total time, including penalty, in the time column of worksheets as called out by the timekeeper, indicating No Time, with NT and No Show with NS, indicating a contestant failed to show up to ride.
  - b.** Record the penalty, if any in the penalty box.

##### **D. Awards Recorder**

- 1.** Number required one (1) or more.
- 2.** Equipment- Awards required.
- 3.** Duties
  - a.** Determine first through sixth for each class in each event by lowest time receiving first place, second lowest time, second place etc.
  - b.** Record placing on worksheets.
  - c.** Prepare awards (Ribbons, etc.) for distribution to winners.

##### **E. District Secretary.**

Even though the above officials may be appointed by the district and/or a specific club within the District, those work details are under the supervision of, and the responsibility of, the district secretary.

##### **1. Duties**

- a.** Entry forms for contestants.
- b.** Running order of contestants for announcer.
- c.** Prepare awards for winners.
- d.** Playday worksheets

1. Record times, places, and points.
  2. List date and location of play day
- G. Line-up Judge:** May disqualify a rider for: running with an open gate; or not breaking forward motion.
1. Number required one or more per gate, as necessary.
  2. Duties
    - a. Entrance gate, open gate for contestants to enter and close gate as per Rule 4 E.
    - b. Exit Gate, Open gate after the contestant has completed his ride and gotten his horse under control. Refer to Rule 4 E. Note Entrance and exit gates may be the same. Where a permanent L shaped gate is provided by an arena, the gateman is not needed.
- H. Arena Officials** Refer to specific Game
- I. Arena judges** to be Intermediate of above.
- J. Judges** for a highpoint run off during Playday Finals must be selected by the playday chairperson from the representatives that are on the rules committee.

**RULE 6 Penalties- Refer to specific Playday Games**

**RULE 7 Disqualifications**

- A.** Striking a horse with playday equipment will disqualify rider for the event in which he is participating at the time
- B.** Failure to be ready to ride on the third call by the announcer.
1. A rider may move up or down within the age group until the end of the age group. If the rider is the last rider, the rider has 5 minutes, in the event of a conflict the rules chairman has the authority to override the 5 minutes to give the rider more time. After that, either ride or be disqualified. Riders can only move up or down with good cause to be determined by the gate judge. If the time malfunctions, that rider may either ride immediately or drop down ten to re-ride. If the rider is at the end of the class, the rider may have 5 minutes. If the rider is peewee or younger, a parent is to make the decision.
- C.** Refer to Article VII Section 8 A
- D.** Refer to Article VII Section 8 B (Disqualification under this rule is for the entire playday.
- E.** Refer to Article VIII Section 8 C
- F.** Refer to Playday Games Rule 4 E closed Arena

**RULE 8 Playday Finals**

The top contestants from each district compete for personal and district recognition awards.

- A.** Qualification for Playday Finals Competition: To qualify for finals, you must have ridden at the District level in each event in which you wish to participate in. Each district may send as many participants as are qualified in each class for each event. A qualified ride is one in which the contestant is not disqualified.
- B.** Representation: A family may represent only one district at Playday Finals.
- C.** Pre-Registration: It is the responsibility of each district to submit names and required fee (registration and entry) of the qualified contestant participating in the playday finals, as indicated by the results of the district playdays, to the Association office and must be postmarked by May 20<sup>th</sup>. Entries can be made after the 21 days and up to noon on Tuesday **for a fee of \$50.00 per entry**. Their name will not be in the program, riders will not be put in rotation but ride at the bottom of the class. No Refunds.
- D.** Equipment: All approved equipment used at Playday Finals will be furnished by the Association in the following colors.
1. Poles-White
  2. Flag Sticks- Natural color(with red material for flag)
  3. Barrel protectors are official equipment
  4. Barrels- A combination of two colors with blue predominant
  5. Electronic Timer
  6. Baseball Barrel
  7. Baseball/ Golf balls
- E.** Running Order: The officers will ride at the top of their class. Chairpersons have the option of riding after officers in line up, but have to declare intentions when signing up for Finals. For the rest of the contestants, a random

draw will be made in each class in each event. The late entries will be excluded from the random sort running order.

- F. Rules Committee:** Any questions presented to the rules committee must be presented by regional rules committee men. Playday rules clarification meeting has one representative from each district. The Playday rules committee shall be made up of two representatives from each region, each from a different class. Each District must have a rules person and one alternate on the grounds at all times during events. Each region shall have a representative present at any protest meeting.
- G. Awards:**
  - 1. Individual Awards:**
    - a.** High Point awards in each class.
    - b.** First through 6th place in each class in each event.
    - c.** After places one through six high point awards have been secured, awards are open to clubs, districts, etc. to donate places seven through ten high point awards. These awards are at the discretion of the awards chairperson and are not to exceed the value of sixth place.
    - d.** As of Convention 2023 Daily Awards will be given to everyone.
- H. Recreational Vehicles (excluding campers):** will not be allowed at Playday Finals subject to the following:
  - 1.** Exception- Official use, and before games begin, and after they are over for the day, until 11:00 pm.
- I. Licensed Vehicle:** At all Association functions licensed vehicles must be driven by licensed Drivers. Reckless driving will be dealt with (head of security).
- J. Protest Fee:** A \$100.00 cash only protest fee along with a protest in writing will be used. This means that if a person puts up \$100.00 and a protest in writing, and he loses, the money is kept by the Association. If he wins, he is refunded his \$100.00. Protests must be made within 10 minutes of the conclusion of the class. The person who files the protest must go to the announcers stand within 10 minutes of the end of the class to file it before it goes to the playday chairman. The protest committee meeting will be held in the office and only the protestor and the protestee and the protest committee can attend. However if individual parties are named, both the protestor and the one protested against must be present at the protest meeting.
  - 1.** If a protest is lodged and a Region Rulesman has a family member that rides in the class being protested, said Rulesman must recuse himself from the meeting and the other appointed Region Rulesman from that Region shall attend the rules meeting to vote on the validity of the protest. If both Rulesmen have family members in the class under protest, their Region VP will immediately appoint an alternate rulesman to attend the protest meeting for vote. If the Rules Chairperson has a family member involved in a protest, he will present the protest and then immediately excuse himself from the meeting before any discussion begins. In this case, the rulesmen in attendance will select an Interim Chairperson until the protest is decided. The judge's decision is final and not a valid reason for a protest.
- K.** If an individual, club or business donates \$650 towards a saddle at PDF, they will be awarded 2 rider entries for free at PDF.
- L.** It takes no less than 3 riders in an age class to qualify for a full class. If there is only one or two riders in an age class, male or female, this will not form a class at PDF. The rider must choose to ride in the same age bracket with the opposite gender or choose to move up a class within the same gender.
- M.** As of 2020 Convention – PDF will be held for 4 days: Wednesday, Thursday, Friday and Saturday. 2 events to be run each day.

## CURRENT PLAYDAY GAMES

### BARREL RACE

This is a timed event. Rider will cross the timer line, make a 360 degree turn around the first barrel, go across the arena, make a 360 degree turn around the second barrel, then make a 360 degree turn around the third barrel and return between first and second barrels, crossing the timer line. This is known as a clover leaf barrel pattern. Riders may run either the right or left pattern.

#### EQUIPMENT REQUIRED

1. Timer line (designates the beginning and ending of each race marked by chalk or lime).
2. Three (3) 55-gallon standard oil drums with the dimensions being 23 inches from outside to outside on the ends and 34-1/2 inches long from the outside lip on top to the outside lip on bottom, placed in a triangle formation ninety (90) feet apart for a cloverleaf pattern. First and second barrels are sixty (60) feet from the timer line. Measurements should be taken from the center of barrels. Barrels must be a minimum of fifteen (15) feet from any arena fence.
3. Barrels must have barrel protectors.

#### PENALTIES

A five (5) second penalty will be added to the rider's time for knocking over a barrel.

#### DISQUALIFICATIONS

1. Breaking the pattern.
2. Failure to complete the race.

#### OFFICIALS

There needs to be at least 2 judges in the arena standing at all times during the event to observe patterns and set up any barrels in their proper place when knocked over.

#### PATTERN ADJUSTMENTS

Adjustment for non-standard arenas. See the arena size diagram preceding games. The arena that is too large creates no problem because the standard pattern can always be used. The arena that is too narrow can be adjusted by placing number one (1) and number two (2) barrels at the fifteen (15) foot minimum distance from the fence, then measuring the distance between the one and two barrels and subtracting from the total standard pattern of 270 feet.

Number three (3) barrels should be placed half of this distance from number two (2) barrel. The triangle totaling 270 feet.

Example: 100 foot arena - 30 feet ( 15 feet each side) = 70 feet.

270 feet - 70 feet = 200 feet.

200 feet divided by 2 = 100 feet.

Third barrel is 100 feet from the first and second barrels.

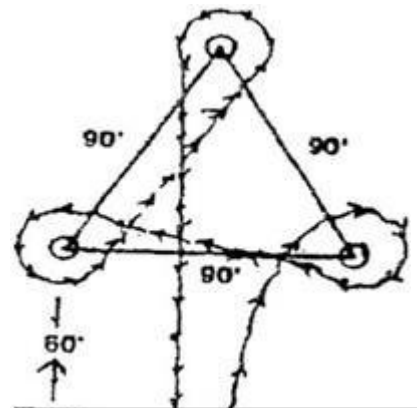

Start and Finish Line

## STRAIGHT AWAY BARRELS

This is a timed event. Rider crosses timer line weaving either right or left of first barrel, continuing weaving in and out to the third barrel, 360 degree turn around third barrel, then weaves back thru barrels to cross the timer line.

### EQUIPMENT REQUIRED

1. Timer line (designates the beginning and end of each race marked by chalk or lime).
2. Three (3) 55 gallon standard oil drums with the dimensions being 23 inches from outside to outside on the ends and 34-1/2 inches long from the outside lip on top to the outside lip on bottom, placed (50) feet apart and third barrel 150 feet from the timer line.
3. Barrels must have barrel protectors.

### PENALTIES

A five (5) second penalty for knocking over the barrel.

### DISQUALIFICATIONS

1. Breaking the pattern
2. Failure to complete the race.

### PATTERN ADJUSTMENTS

Adjustments for non-standard arena - none

### JUDGES

There needs to be at least 2 judges in the arena standing at all times during the event to observe pattern and set up any barrels in their proper place when knocked over.

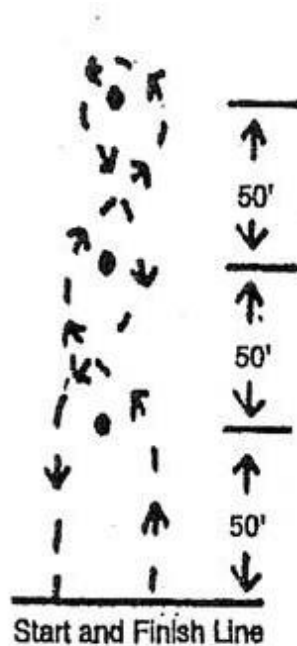

## PYLON ALLEY

This is a timed event. The rider crosses the timer line between the cones in the first and second set, makes a turn around the center cone (of the last three) and returns, going between the cones in the second and the first set. A left or right turn may be made around the center cone.

### EQUIPMENT REQUIRED

1. Timer line (designates the beginning and ending of each race marked by chalk or lime).
2. Seven (7) traffic cones with the size of base being 10-1/2 inches to 12" from outside to outside with the height being 17 inches tall. The first set of cones are six (6) feet apart and twenty (20) feet from the timer line, the second set are six (6) feet apart and forty (40) feet from the timer line, and the last three (3) cones are six (6) feet apart and sixty (60) feet from the timer line.
3. Cones are to be measured 6' from top center of the cone to top center of the cone.

### PENALTIES

The only penalty is disqualification.

### DISQUALIFICATIONS

1. Breaking Pattern
2. Failure to complete the race.
3. Any leg of the horse passing over any cone rather than around the cone.
4. Knocking over any cone

### OFFICIALS

Three (3) judges, one to observe the first set of cones, one to judge the second set of cones and one to judge the last three cones.

### PATTERN ADJUSTMENTS

Adjustments for non-standard arena – none

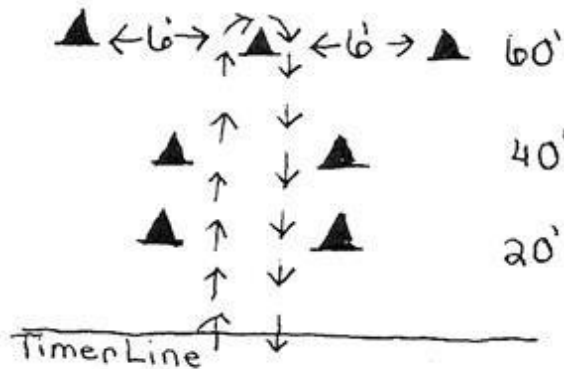

## SPUR

This is a timed event. The horse and rider must go through the first set of pylons, make a 360 degree turn around the pole, through the second set of pylons. Race may be run from either a right or left pattern

### EQUIPMENT REQUIRED

1. Timer line (designates the beginning and end of each race marked by chalk or lime.)
2. 5 traffic cones with the size of base being 10-1/2 inches to 12" from outside to outside with the height being 17 inches tall. Center cone should contain a standard pole with base (see Quarter Horse Poles for dimensions). Center cone is placed 120 feet from the start/finish line and centered in the arena. Two (2) gates are formed, one on each side of the arena, with 2 cones used for each gate. The cones forming the gates are set 10 feet apart, and 10 feet from the start/finish line, and 30 feet from centerline of arena, to leave 60 feet between the two gates. All measurements made from the inside base of cones.

### PENALTIES

None

### DISQUALIFICATIONS

1. Knocking over anything.
2. Breaking pattern

### PATTERN ADJUSTMENTS

Adjustments for non-standard arena - None

### Judges

There needs to be at least 2 judges standing at all times to observe the pattern.

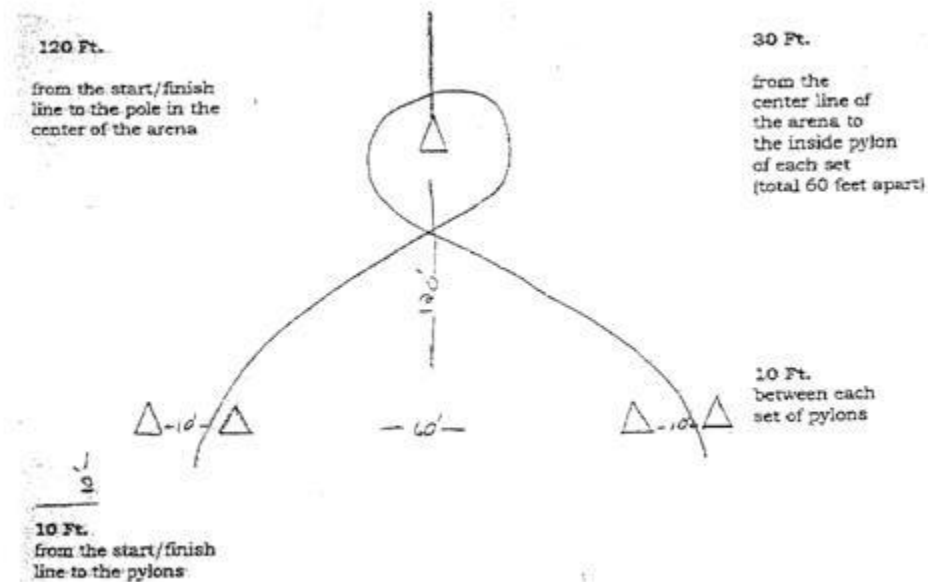

## QUARTER HORSE POLES

This is a timed event. The pole bending pattern is to be run around six (6) poles. The rider starts either right or left, runs to the sixth pole, pivots, starts weaving in and out to number one (1) pole, pivots around number (1) pole, weaving in and out to number (6) pole, pivots, and then back over the finish line. See pattern. Poles are placed twenty one (21) feet apart with the first pole (21) feet from the starting line.

### EQUIPMENT

1. Timer line (designates the beginning and end of each race marked by chalk or lime).
2. The base will be a minimum of 14" to a maximum of 17" diameter.
3. The poles will be a minimum of 6 feet and a maximum of 7 feet in height.
4. PVC cap on the top of each pole.
5. Bases to weigh a maximum of 12 lbs.
- 6 Six poles made of PVC pipe, a minimum of 1" to a maximum of 1 1/2" in diameter.

### PENALTIES

Five second penalty for knocking over a pole

### DISQUALIFICATION

1. Failure to complete race
2. Breaking the pattern

### Judges

There should be at least 3 judges standing in the arena at all times. One should stand at the end of the poles and one on either side of the poles to observe patterns and set up any proper place.



## DOUBLE BARREL FLAG RACE

This is a timed event. The rider crosses the timer line, passes the middle barrel going behind it. He picks up the flag from the bucket on the middle barrel and places it in the bucket on an outside barrel and returns back across the timer line. Riders may run right or left and may circle any and all barrels within the correct pattern.

### EQUIPMENT REQUIRED

1. Timer line (designates the beginning and ending of each race marked by chalk or lime).'
2. Three (3) 55 gallon standard oil drums with the dimensions being 23 inches from outside to outside on the end and 34-1/2 inches long from the outside lip on top to the outside lip on bottom, spaced twenty (20) feet apart and 152 feet from the timer line with three (3) rubber buckets (2 or 3 gallon size without obstructions, such as bails or ears), filled with sand to the top, one placed on each barrel. Bucket will be set on the back of the barrel and the flag in center of the bucket
3. The barrels must have protectors.
4. Two (2) 6x8 inch flags of red color.
5. All flag sticks will be 14" long by 1/2 inch in diameter tapered on the end and will be natural in color.

### PENALTIES

Only penalties are disqualifications.

### DISQUALIFICATIONS

1. Breaking the pattern
2. Failure to complete the race.
3. Flag falling from the bucket.
4. Knocking over a barrel or bucket. .
5. Failure to place flag in bucket.

### OFFICIALS

Three (3) judges, one at each barrel to observe the pattern and replace the flags before each contestant runs.

### PATTERN ADJUSTMENTS

Adjustment for non-standard arena – none

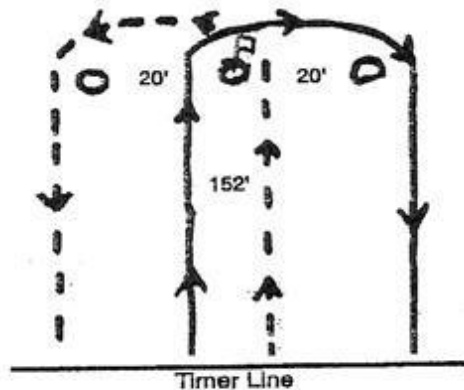

## BASEBALL

This is a timed event. Rider races to the barrel and picks up the baseball while turning the barrel, then returns to the barrel nearest the finish line, depositing the baseball in it before crossing the finish line. Riders may run either the right or left pattern. A rider may circle either barrel as long as the rider comes in one side and goes out on the other without running a figure eight.

### EQUIPMENT REQUIRED

1. One (1) 55 gallon standard oil drum, with the dimension being 23 inches from outside to outside on the end and 34-1/2 inches long from the outside lip on top to the outside lip on bottom, placed 152' from the timer line.
2. One (1) three (3) gallon black rubber bucket without obstructions such as a bail or ears completely filled with sand placed on top of the 55 gallon drum at the back side (furthest edge away from the timer line)
3. Baseball: A standard major league baseball to be placed on the sand in the center of the bucket for each contestant. Golfball: Optional for riders in SuperPeeWee and PeeWee classes
4. One (1) regular 30 gallon drum placed 20' from the timer line (in line with and between the other barrel and the timer line.) This barrel has an open top and bottom.

### DISQUALIFICATIONS

1. Breaking the pattern such as doing a figure eight.
2. Failure to pick up the ball
3. Dropping ball
4. Ball touching the 55 gallon barrel or ground due to actions of horse or rider
5. Failure to deposit ball in goal barrel
6. Failure to complete the race
7. Knocking over bucket or barrel
8. Ball not in barrel upon completion of ride.

### OFFICIALS

Two (2) judges, 1 at each barrel. In addition to judging, they are responsible for placing the baseball on the sand-filled bucket and removing the baseball from the goal barrel after each ride.

### PATTERN ADJUSTMENTS

Adjustments for non-standard arena: none

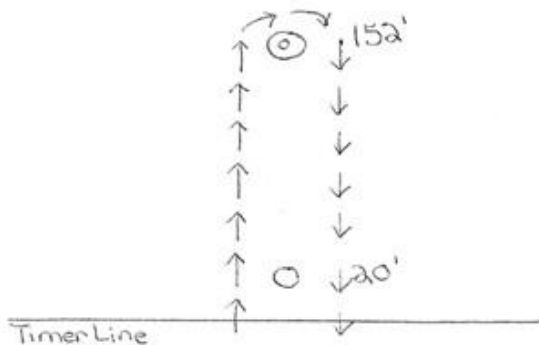

## FLYING W RACE

This is a timed event. The Flying "w" race is run with the same poles as used in the Quarter Horse Poles. See diagram below for measurements. Riders may run either a right or left pattern. Rider races to the first pole, turns it, weaving each pole, turns the last pole, and returns crossing the finish line.

### EQUIPMENT

1. Timer line (designates the beginning and end of each race marked by chalk or lime).
2. The base will be a minimum of 14" to a maximum of 17" in diameter
3. The poles will be a minimum of 6 feet and a maximum of 7 feet in height.
4. PVC cap on the top of each pole
5. Bases to weigh a maximum of 12 lbs.
6. Five poles made of PVC pipe, a minimum of 1" to a maximum of 1 1/2" in diameter.

### PENALTIES

A five second penalty for each pole knocked over.

### DISQUALIFICATIONS

1. Failure to complete the pattern
2. Breaking the pattern

### Judges

There needs to be at least 2 judges in the arena standing at all times to observe patterns and set up any poles in their proper place when knocked over.

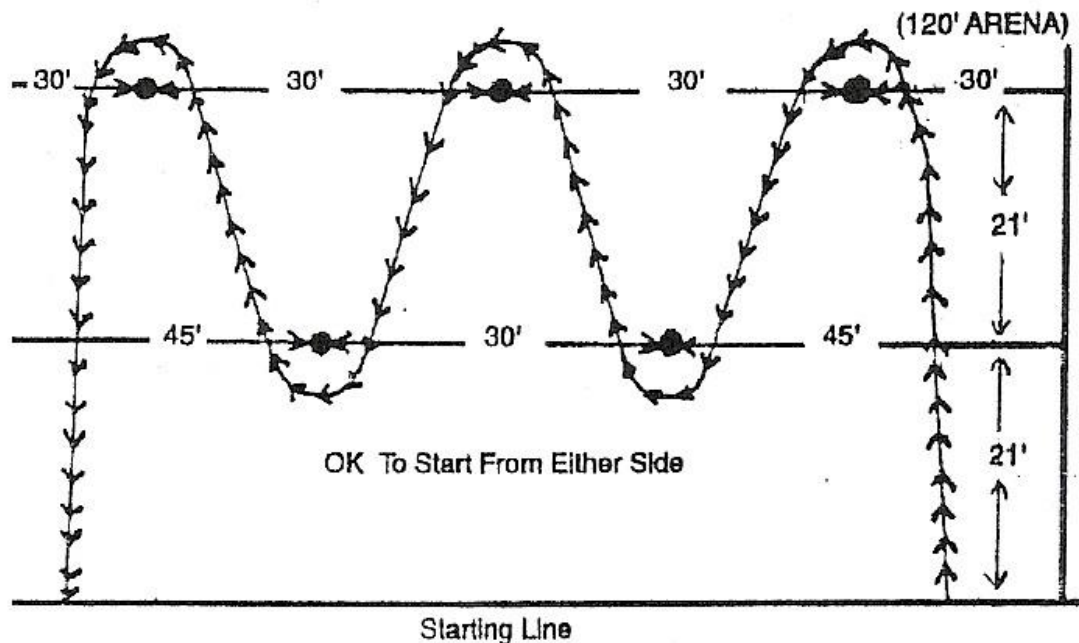

## LAZY H

This is a timed event. Rider will cross the timer line and go thru the set of cones to the left pole and make a 360 degree turn around the pole and go straight across to the right pole and make a 360 degree turn around. Then the rider will proceed back thru the set of cones to the right barrel and make a 360 degree turn around and then make a figure 8 to the left barrel and make a 360 degree turn around and then runs to cross the timer line. The event can be run either left or right.

## EQUIPMENT

1. Timer line
2. Two (2) Poles
  - a. The base will be a minimum of 14" to a maximum of 17" diameter.
  - b. Pole will be a minimum of 6 feet and a maximum of 7 feet in height.
  - c. PVC cap on the top of each pole.
  - d. Bases to weigh a maximum of 12 lbs.
  - e. Poles made of PVC pipe, minimum of 1" to a maximum of 1 1/2" in diameter.
3. Two (2) Cones
  - a. The base will be 10 1/2" outside to outside" and 17" tall.
4. Two (2) 55-gallon drum barrels with protectors.

## PENALTIES

1. A five second penalty will be added to the rider's time for each barrel, cone or pole knocked over.

## DISQUALIFICATIONS

1. Failure to complete the race.
2. Breaking the pattern.

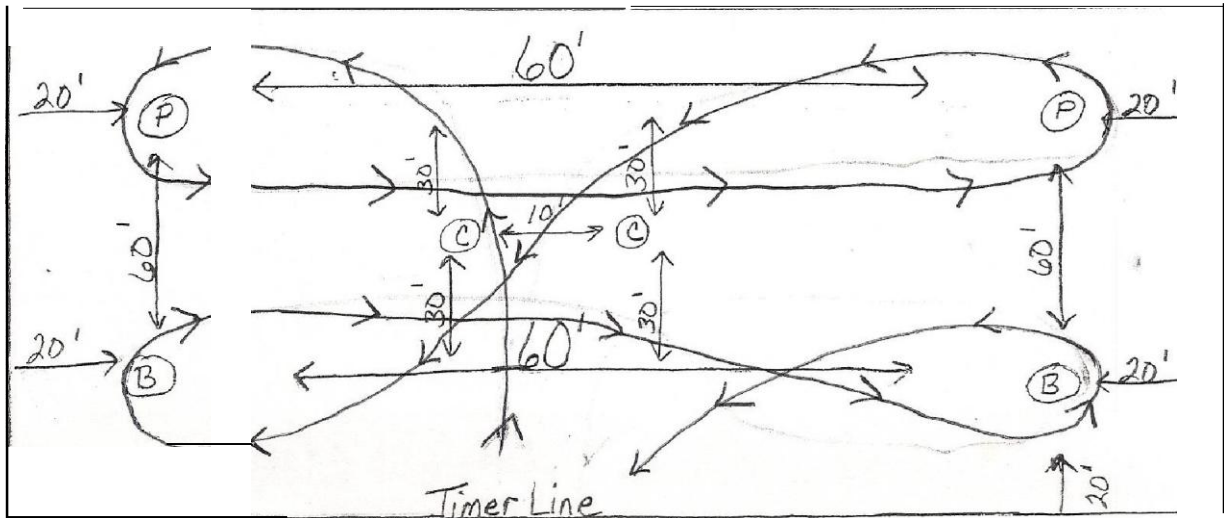

## PEPPERMINT TWIST

me rreer polt:s ano spnms w mt umer une.

Peppermint Twist

### Equipment

1. Timer Line
2. Three Poles
  - A. The base will be a minimum of 14" to a maximum of 17" diameter.
  - B. Pole will be a minimum of 6 feet and a maximum of 7 feet in height.
  - C. PVC cap on the top of each pole.
  - D. Bases to weigh a maximum of 12 lbs.
  - E. Poles made of PVC pipe, minimum of 1" to a maximum of 1 1/2" in diameter.
3. Two (2) 55-gallon drums and must have barrel protectors.
4. The number one and two barrels must be at least 15 feet off the fence.

### Penalties

1. A five second penalty will be added to the rider's time for each barrel or pole knocked over.

### Disqualifications

1. Failure to complete the race.
2. Breaking pattern.

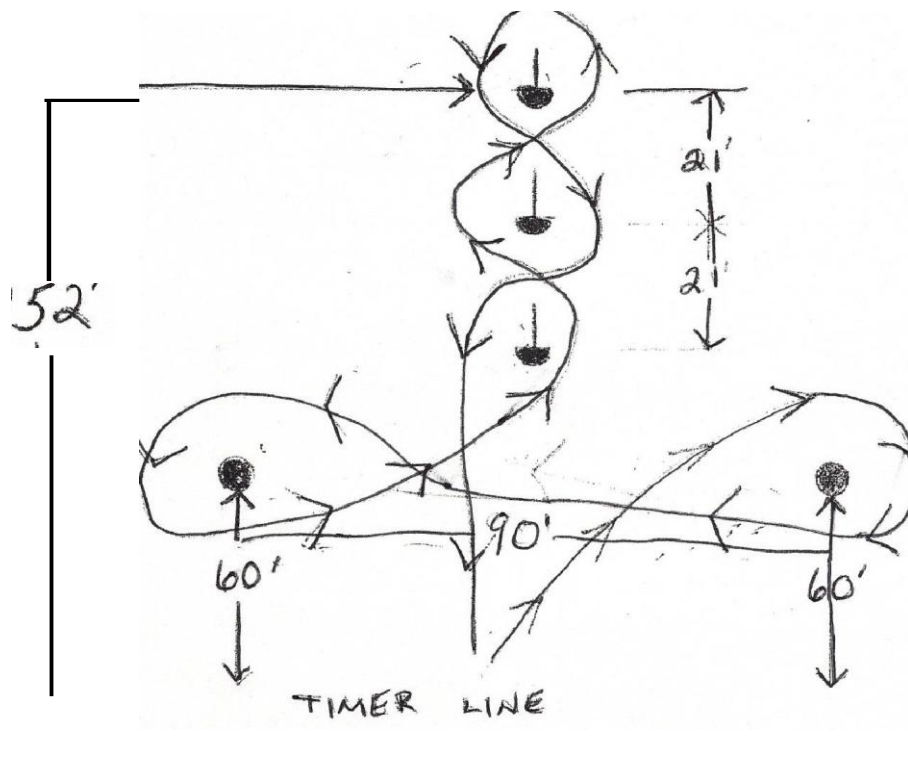

## HITCH & GO

Rider crosses timer line going between the first two (2) poles. Proceed to the next set of poles, either to the right or left pole. Going to the inside of the chosen pole, make a 360 degree turn around the pole. Proceed across the arena to the opposite pole and make same (right/left) 360 degree turn, finishing on the inside of the pole. Finish the pattern by going back through the first two (2) poles to the finish line.

### Equipment Required

Four (4) standard poles

### Measurements

1. First two (2) poles are ten (10) feet from the starting line ten (10) feet apart, measured from the center of the poles and the center of the arena.
2. Second two poles are fifty-five (55) feet from the starting line and sixty (60) feet apart, measured from the center of the poles and the center of the arena.

### Penalties

There will be a five (5) second penalty for knocking over a pole.

### Disqualifications

Failure to run a correct/complete pattern will be a disqualification.

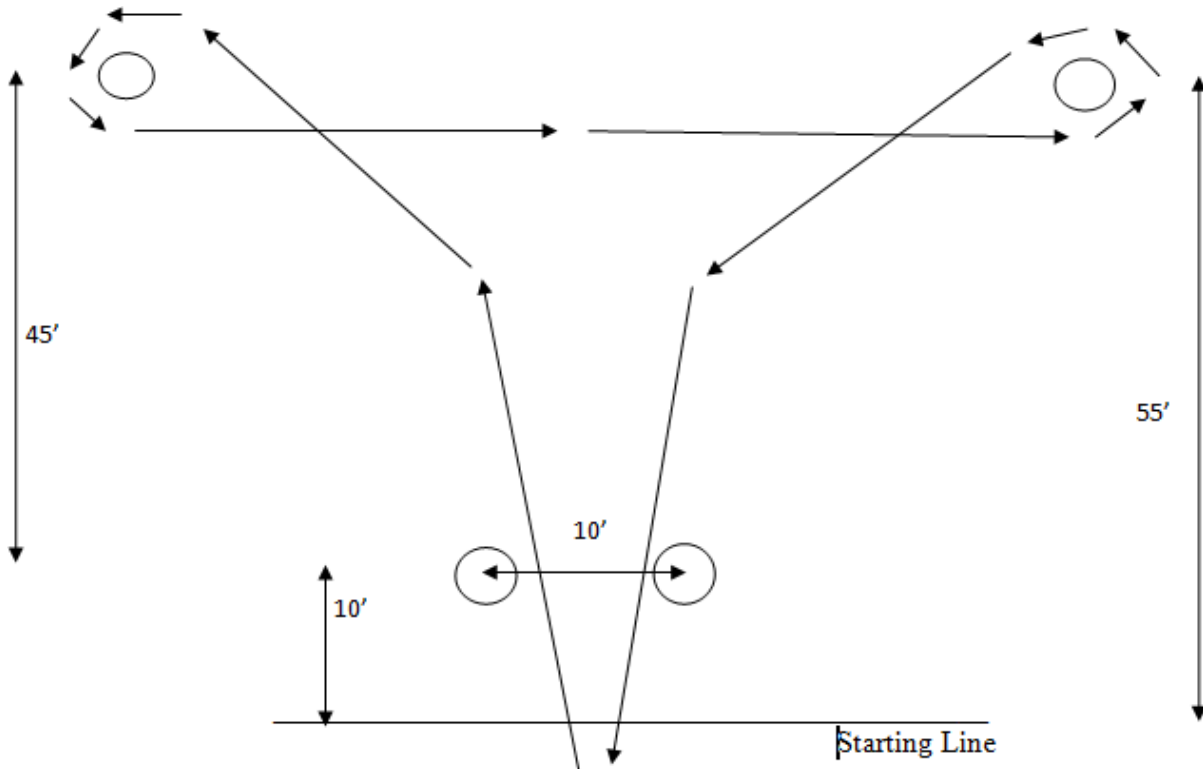

## LARRYETTE

Rider crosses the timer line either to the right or left set of poles. Rider goes on the outside of the first pole, inside the second, outside the third. Going around the barrel, rider proceeds to the second set of poles, going outside the first, inside the second and outside the third and crosses the finish line.

### Equipment Required

Six (6) standard poles

One (1) fifty-five (55) gallon barrel with barrel pad

### Measurements

Poles are thirty (30) feet between each going down the arena

Poles are sixty (60) feet apart across the arena

Barrel is centered in the pattern and thirty (30) feet from the last poles

### Penalties

There will be a five (5) second penalty for knocking each pole or the barrel.

### Disqualifications

Failure to run a correct/complete pattern will result in disqualification.

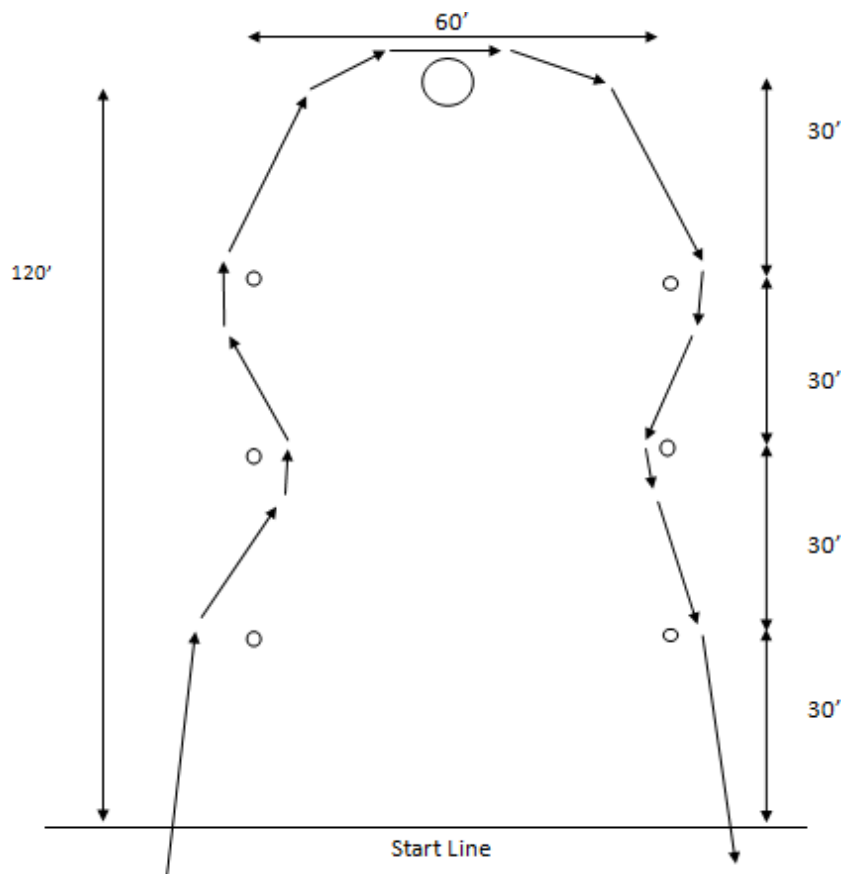

## BOW TIE

### A timed event

Pattern for run beginning on left side of center cone: Rider crosses timer line, curves right passing center cone (on the left side) to right turn around both upper and lower cones, then back on the right side of the center cone, curving left (passing center cone) to left turns around both upper and lower cones, then to the left side of center cone, making a right turn around center cone and back across the timer line.

Pattern for run beginning on right side of center cone: will be curve left, two left turns, passing center cone on the left to two right turns, back to left turn of the center cone and across timer line.

### PENALTIES

A 5 second penalty for each pylon knocked down.

### DISQUALIFICATION

Failure to complete the pattern, breaking the pattern, or straddling a cone

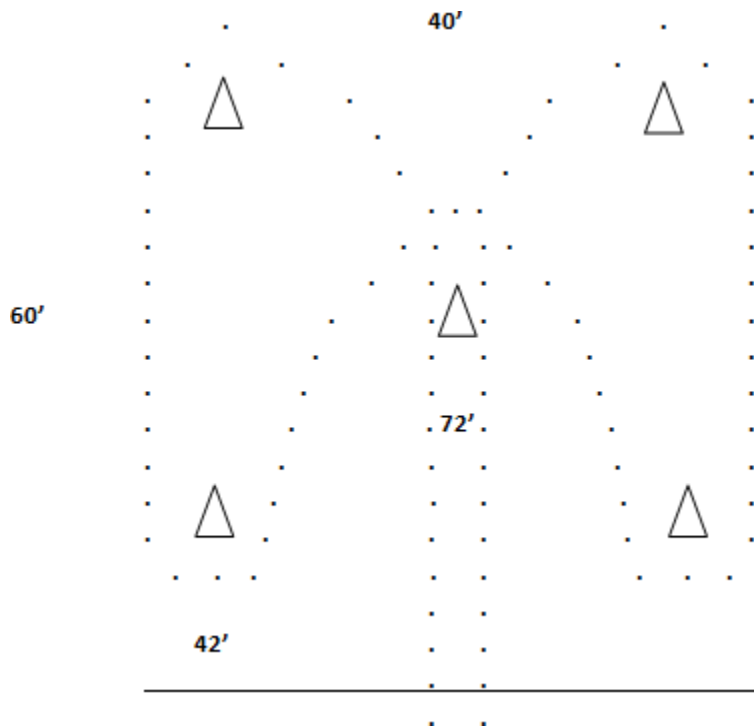

## **HORSEMANSHIP ~ SPORTSMANSHIP ~ CITIZENSHIP**

### **COPYRIGHT AND REVISION DATES**

All rights reserved including the right to reproduce this book or any portion thereof in any form.

This official manual is the sole property of The American Association of Sheriff Poses and Riding Clubs and its members only.

Copyright February 1953  
Revised July 1954  
Revised January 1955  
Revised June 1956  
Revised December 1957  
Revised December 1958  
Revised December 1959  
Revised December 1960  
Revised January 1964  
Revised January 1967  
Revised March 1970  
Revised January 1971  
Revised January 1972  
Revised May 1973  
Revised January 1975  
Revised January 1977  
Revised February 1985  
Revised January 1992  
Revised July 1994  
Revised April 1997  
Revised May 1998  
Revised October 1998  
Revised January 2001  
Revised March 2003  
Revised December 2004  
Revised October 2005  
Revised October 2008  
Revised January 2009  
Revised January 2010  
Revised October 2010  
Revised October 2012  
Revised January 2013  
Revised January 2014  
Revised January 2016  
Revised January 2017  
Revised January 2018  
Revised January 2019  
Revised January 2020  
Revised January 2021  
Revised January 2023  
Revised January 2024